



**Moulded Case
Circuit Breakers**



Solutions for diverse application.

Stability: Activated



In every industry, big or small, electrical power supply is critical. Even a few seconds of interruption or instability can result in huge financial losses, even loss of life. We have little or no control over the nature or stability of power supply. The unpredictable nature of power makes it important to take appropriate steps for the protection and safety of your organisation's employees and equipment.

In line with this objective, Larsen & Toubro presents dsine – a highly advanced and sophisticated range of Moulded Case Circuit Breakers (MCCBs).

The dsine range, a new generation of MCCBs, is a combination of state-of-the-art design and modern user-friendly features. It also boasts a wide choice of protective releases, ergonomics, aesthetics and compactness. The range, designed to meet the changing needs of users after extensive analysis and user feedback, can satisfy the most demanding system requirements.

Complemented by a wide array of accessories, the dsine range offers comprehensive solutions to customer applications ensuring operational safety, reliability and versatility.



dsine
**Moulded Case
Circuit Breakers**



L&T – Turning technology to your advantage

Over the last five decades, L&T has earned a place among the world's leading manufacturers of Low Voltage Switchgear with the scale, sophistication and range to meet global benchmarks.

In keeping with our leadership position in the Indian market, we also provide expert assistance in product

selection, installation and effective after-sales service, across the country.

L&T is one of the first companies to introduce MCCBs in India. Over the years, we have developed our products to meet the ever-evolving demands of the market.

Obstacles: Deleted



010101010101001

Original Equipment Manufacturers (OEMs)

For Original Equipment Manufacturers (OEMs), every moment poses a new challenge. The dsine range of MCCBs has been created keeping this in mind. Built in accordance with the highest technical standards, dsine MCCBs assure reliable and maintenance-free operation. They have been designed to adapt to changes and overcome the challenges of your day-to-day operations.

Besides being available in 4P version to serve OEMs, such as DG sets, dsine MCCBs come with an external neutral CT for the microprocessor-based version to offer neutral

and earth fault protection with 3P MCCBs. Equipped with common accessories for the entire range, these MCCBs assure excellent savings by reducing your inventory costs.

What's more, our experienced sales & service team is just a call away. Our team is adept at handling queries and complaints and is trained to offer you techno-commercial solutions... on time, every time.

After all, forging long-term associations has always been the cornerstone of our business.

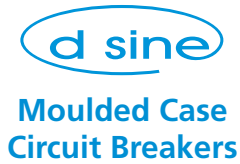

Versatility: Downloaded



Paper Industry



Sugar Industry



Oil Industry



Gas Industry

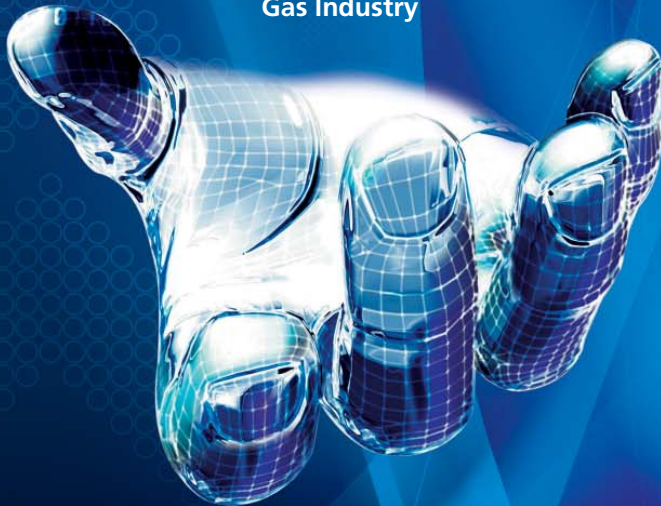

Industries

Every industry is unique, and so are its requirements. Industries as diverse as paper, sugar, oil & gas have different sets of needs. Thankfully, dsine MCCBs, available in various current ranges (20A to 1250A), are designed to efficiently handle such diversity.

Our Thermal Magnetic as well as Microprocessor-based releases with various breaking capacities cater to multiple industrial needs. Built with the latest technology, dsine MCCBs deliver optimum efficiency even in the most adverse environmental conditions.

MCCBs with high breaking capacities cater to high voltage applications such as windmills and mines. They are compact so the panel builder can optimise panel size. They are thoroughly factory-tested with adequate quality controls in place. Moreover, since these MCCBs are designed to handle high-value capacitive inrush currents, no nuisance tripping is observed in APFC panels. Motor loads being most vital, our design team has also developed special dsine-M series for motor back-up protection ranging from 32A to 630A.



Efficiency: Initiated

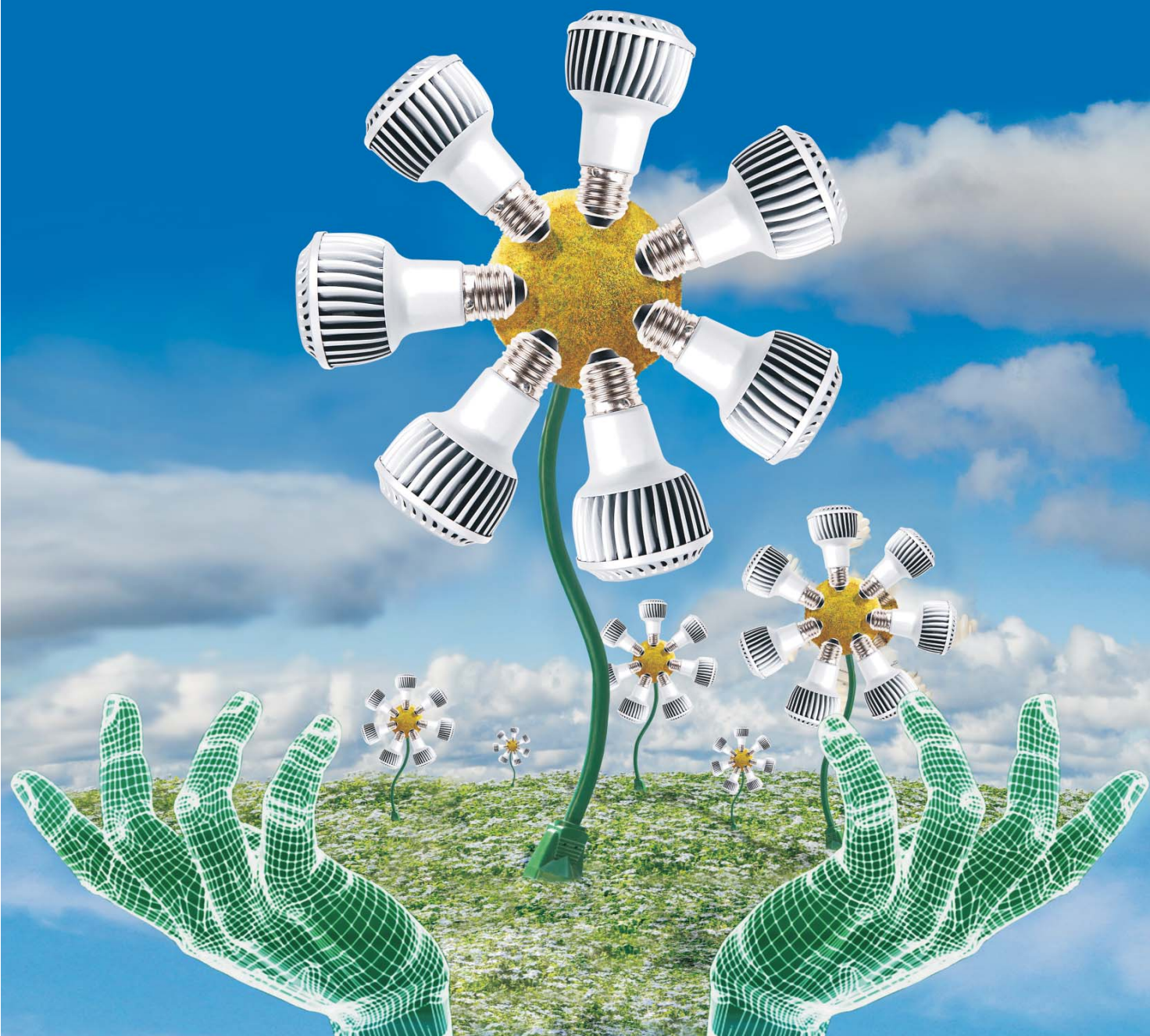

Building Sector

Today, efficient energy management holds the key to growth and development in any sector. Moreover, in most sectors, such as the building sector, energy management has become mandatory. Our new range of dsine MATRIX releases with advanced technology is specially designed with energy management in mind.

MTX3.0 releases with power metering and communication capabilities are ideal for remote annunciation in Data Centers and IT Parks.

Choose from a variety of communication protocols including MODBUS RTU and Bluetooth available with our new MATRIX releases. In today's world of high-end residential buildings or commercial malls, our motorised dsine MCCBs with the fastest changeover from mains to DG in less than 300 milliseconds are indeed the most reliable choice. Our Auto Source Transfer System has almost eliminated the risk of loss of data.



Performance: Delivered



DC Systems, UPS, Battery Chargers

Unlike AC breaking, DC breaking is a critical phenomenon that causes severe damage. That's why, we offer DC MCCBs from the dsine family. A range that has been designed and developed specially for DC applications such as UPS and battery chargers.

Choose from a wide range of DC voltages (up to 500V) and DC breaking capacities (up to 36kA) available as per various application requirements.

They are also available for lower DC voltages such as battery chargers.

The SD (Switch Disconnect) version of dsine MCCBs can be used at the incoming and outgoing terminals of UPS for isolation. Our SD is designed to withstand high currents without compromising on Service Performance.



Reliability: Ensured

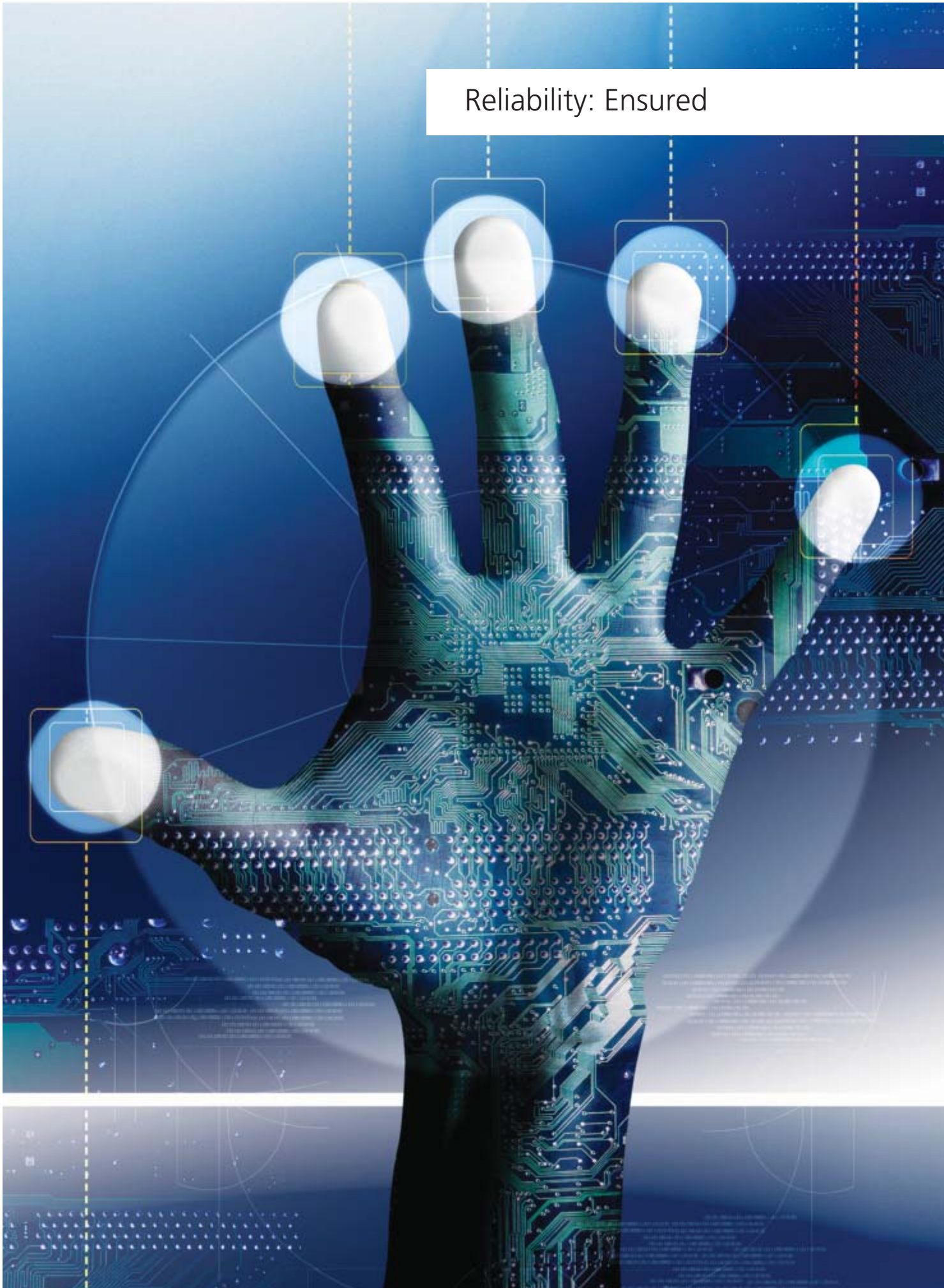

Infrastructure

Monitoring and controlling electrical installations at places like airports, hospitals etc. demands high-end, reliable solutions. MATRIX releases are built precisely for such purposes.

Communication capable MATRIX releases with power and energy metering help in modernisation. These releases are made compatible with HMI (Human Machine Interface) and DCS (Data Control System).

As power supply is critical for airports and hospitals, our dsine MCCBs with ASTS offer changeovers in less than 300 milliseconds coupled with a variety of other protections in case of under voltage, phase unbalance, etc.

A variety of settings in MATRIX releases helps in choosing the correct selection for fault clearing, while trip & event recording with MATRIX releases helps in analysing the faults in detail.

Our dsine MCCBs are shipped to Europe, Africa, Australia, Middle East, South East Asia, China and America. In India, we have the largest stockist network with over 700 stockists. To find the ideal dsine MCCB suitable for your requirements, turn the page.



DN0



DN1



DN2



DN3



DN4

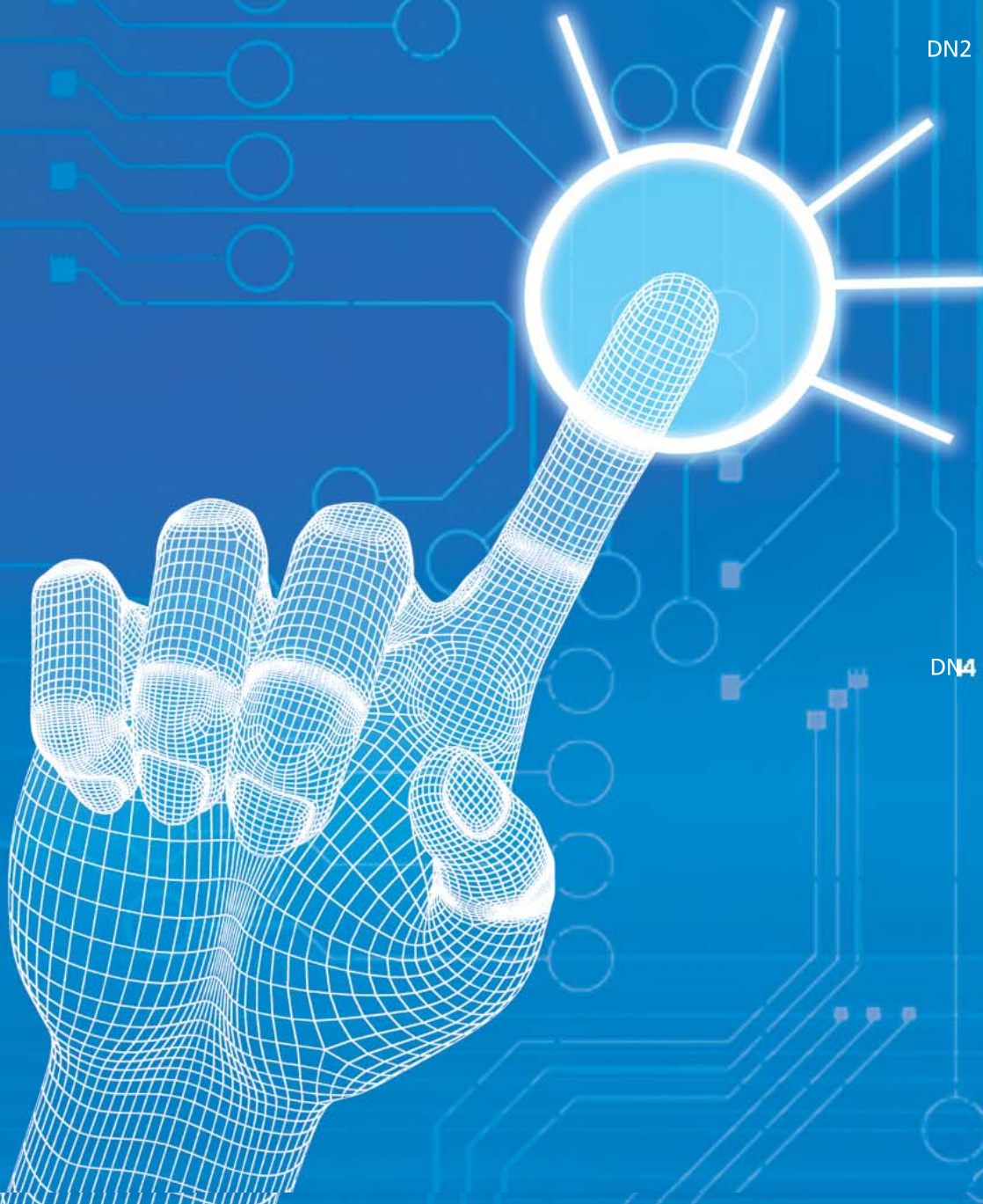

INDEX

15

Overview

25

Product Data

45

Accessories

53

Characteristic Curves

59

Wiring Diagrams

65

Dimensions



Overview

■ d sine Range	16
■ Standards & Approvals	18
■ Structure & Features	19
■ Marking & Configuration	20
■ Trip Units	21
■ Accessories	22



State-of-the-art design, user-friendly features and a wide spectrum of protection releases form the hallmarks of the dsine range. Also recognised for its ergonomics, aesthetics and compactness, it belongs to a new generation of MCCBs. Specially designed and developed for extreme tropical conditions, it promises reliable performance at high ambient and humid environment.

dsine, unfailingly, caters to the ever-evolving needs of customers, derived after in-depth analysis and customer feedback. Because we understand our customers' requirements and demands, our contemporary range of MCCBs never fall short of ensuring complete customer satisfaction. Moreover, complemented by a host of accessories, the dsine range delivers comprehensive solutions to customer applications ensuring operational safety, reliability and versatility.

Features

- Range available from 20A to 1250A
- Available in 3 pole & 4 pole
- Range of 25kA / 36kA / 50kA / 70kA / 100kA breaking capacities
- Microprocessor and Thermal-Magnetic based protection releases
- MCCBs for Motor backup protection
- MCCBs for Distribution and SD versions
- Suitable for DC application
- Manual, Rotary or Motorised versions
- Wide range of common Internal and External accessories
- RoHS compliant

DN0	
Rated Current	20, 25, 32, 40, 50, 63, 80, 100, 125*A
Release	Thermal-Magnetic
DN1	
Rated Current	125, 160, 200, 250A
Release	Thermal-Magnetic
DN2	
Rated Current	63, 80, 100, 125, 160, 200, 250A
Release	Thermal-Magnetic
	40, 63, 100, 160, 250A
	Microprocessor
DN3B	
Rated Current	320, 400A
Release	Thermal-Magnetic
DN3	
Rated Current	320, 400, 500, 630A
Release	Thermal-Magnetic
	400, 630A
	Microprocessor
DN4	
Rated Current	800, 1000, 1250A
Release	Microprocessor

* Available only in DN0-D

Breaking Capacities (I_{cu})

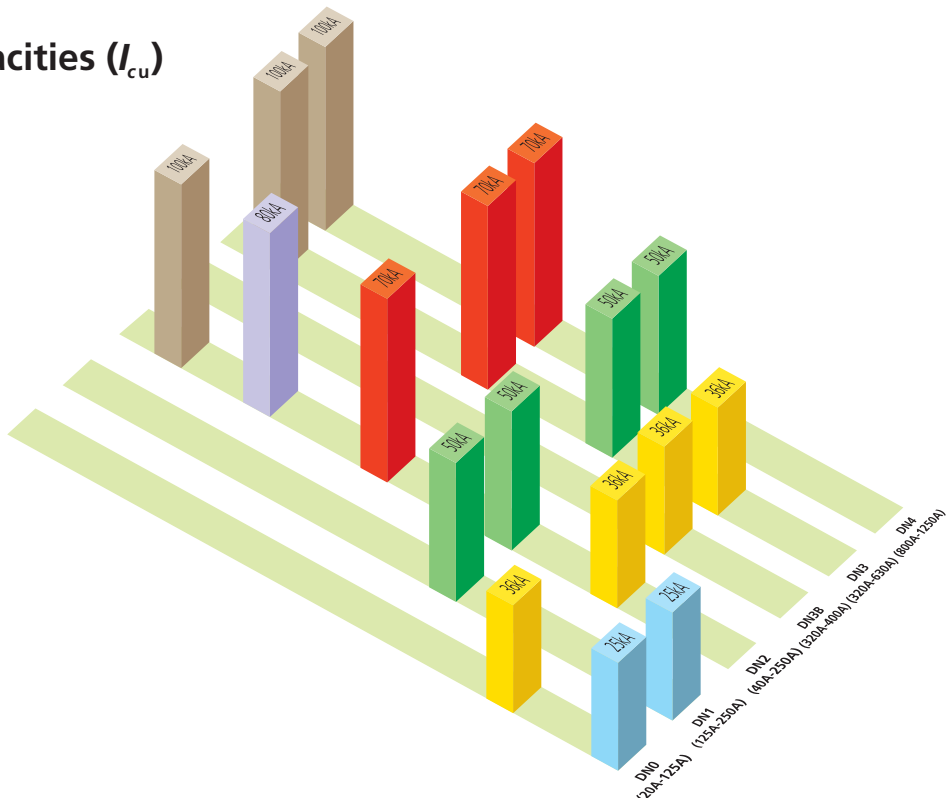

dsine range of MCCBs and Accessories comply with following international standards

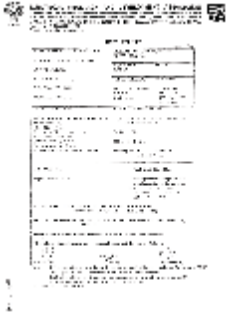

- **IEC 60947-1, EN 60947-1, IS/IEC 60947-1**
Low-voltage switchgear and controlgear, Part 1: General Rules
 - **IEC 60947-2, EN 60947-2, IS/IEC 60947-2**
Low-voltage switchgear and controlgear, Part 2: Circuit-breakers
 - **IEC 60947-3, EN 60947-3, IS/IEC 60947-3**
Low-voltage switchgear and controlgear, Part 3: Switches, disconnectors, switch-disconnectors and fuse combination units
 - **IEC 60947-4, EN 60947-4, IS/IEC 60947-4**
Low-voltage switchgear and controlgear, Part 4: Contactors and Motor-starters
- Third party certificates (ERDA/CPRI) available for dsine range of MCCBs

NABL



NABL accreditation is a formal recognition of the technical competence of testing, calibration or medical laboratory for a specific task following ISO/IEC 17025:2005 Standard. Accredited laboratories have the responsibility of satisfying the criteria of laboratory accreditation at all times, which are verified during Surveillance and Re-assessment visits by NABL. Further the accredited laboratories should prove their technical competence by satisfactory participation in recognized Proficiency Testing Programmes.

L&T's Switchgear Testing Lab is NABL accredited subject to continued satisfactory compliance to above standard & additional requirements of NABL.

All dsine range of MCCBs are tested in L&T's NABL accredited Switchgear Testing Lab.

CE marking



A CE marking is a European marking of conformity that indicates a product complies with the essential requirements of the applicable European laws or directives with respect to safety, health and environment and consumer protection. Generally, this conformity to the applicable directives is done through self-declaration and is required on products in the countries of the European Economic Area (EEA) to facilitate trade among the member countries. The manufacturer or their authorized representative established in the EEA is responsible for affixing the CE marking to their product. The CE marking provides a means for a manufacturer to demonstrate that a product complies with a common set of laws required by all countries in the EEA to allow free movement of trade within the EEA countries.

L&T's dsine range of MCCBs conform to the Low voltage directive 73/23/EEC as amended by directive 93/68/EEC, provided if it is used in the application for which it is made and is installed and maintained in accordance with professional practices with relevant installation standards and operating instructions.

IECEE CB SCHEME – DEKRA (KEMA) certified



The IECEE CB SCHEME is a multilateral agreement among participating countries and certification organizations. A manufacturer utilizing a CB test certificate issued by one of the accepted National Certification Bodies (NCBs) can obtain certification marks of the latter, within their scope of adherence, in the countries where the accepted NCBs are located.

L&T's dsine range of MCCBs are certified for IECEE CB scheme by DEKRA (KEMA) which is a world renowned organisation with a heritage of 150 years in testing, inspections & certification, risk management and verification.

Low Watt Loss

- The entire current carrying path is optimally designed to achieve low watt loss
- Silver contacts offer low contact resistance thus helping in low watt loss



MCCB Mechanism

- Quick make, quick break & trip free mechanism

Positive Isolation

- Indicates the true position of the contacts - ensures operator safety

No Load Line Bias

- Either side of MCCB terminals can be used as load or line

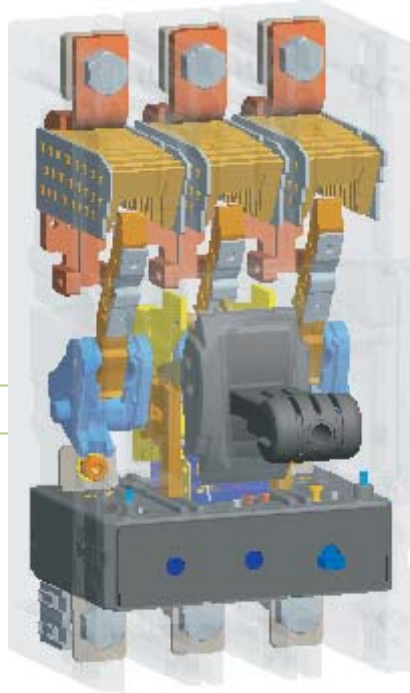
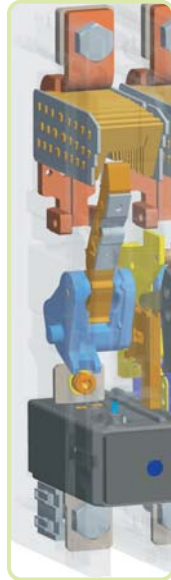

Arc Chutes

- Arc chutes are designed for efficient and faster arc quenching



Current Limiting MCCBs

- The unique speed contact system with current limiting feature accelerates the opening of contacts during short circuit resulting in very low let through energy

Front Fascia

- Knob designed for better grip
- Indicates "ON", "OFF" and "TRIP" position of MCCB

Release

- Thermal & Microprocessor based releases are available

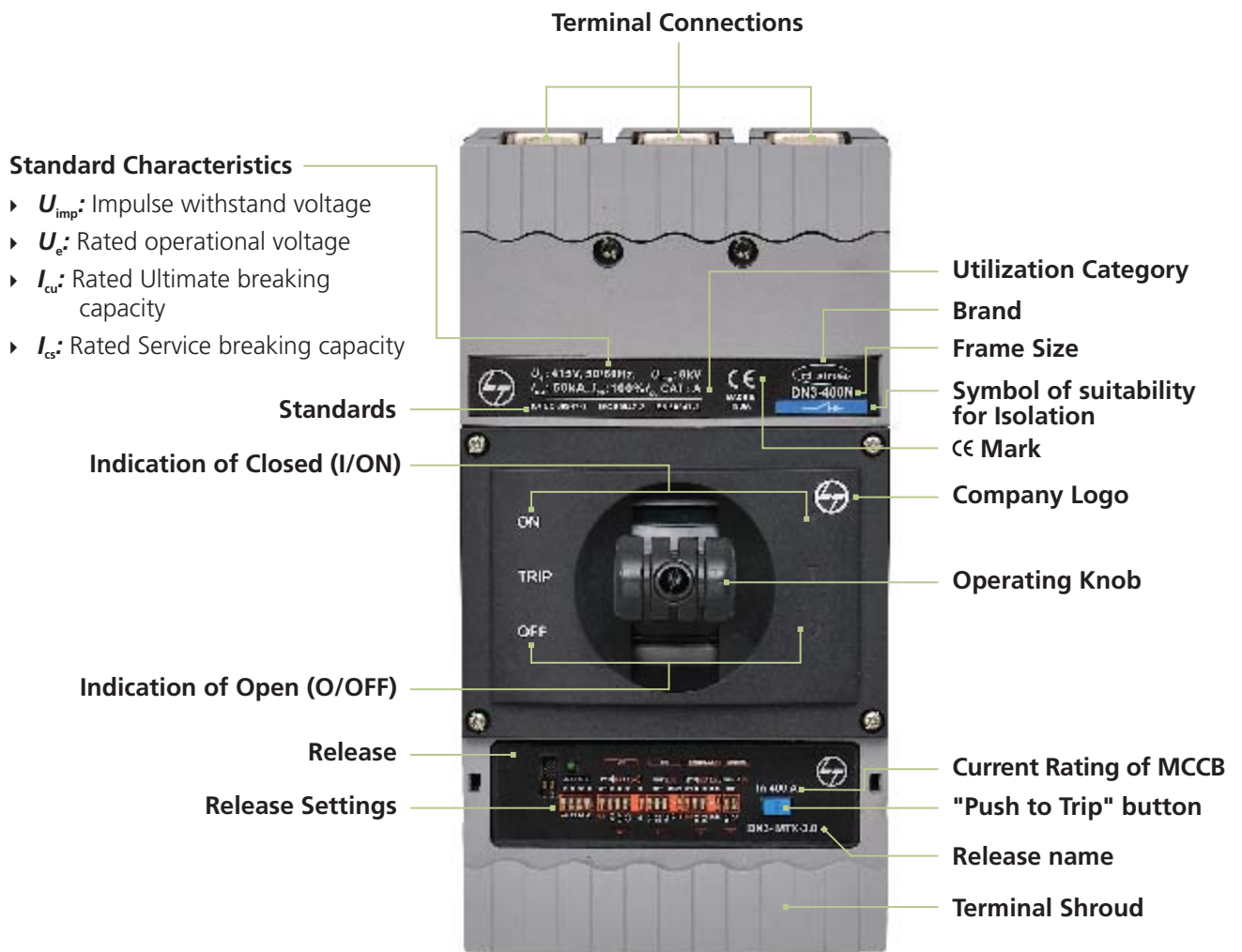

Thermal Magnetic Releases

Variable Thermal, Fixed Magnetic (DN0, DN1, DN3B)



Variable Thermal, Variable Magnetic (DN2, DN3)



MTX1.0 with LSI (DN2, DN3, DN4)



MTX2.0 with LSING + Current Metering (DN2, DN3, DN4)



Microprocessor Releases

MTX3.0 with LSING + Communication capable + Power Metering (DN2, DN3, DN4)



Motor Protection Release (DN0, DN1, DN2, DN3 - Magnetic Protection only)

Magnetic Release



Switch Disconnecter (DN0, DN2, DN3, DN4)

Isolator



- 1 Spreader Terminals
- 2 Phase Barriers
- 3 Undervoltage Release
- 4 Shunt Release
- 5 Auxiliary Contact
- 6 Trip Alarm Contact
- 7 Auxiliary + Trip Alarm Contact
- 8 Direct Rotary Handle
- 9 Extended Rotary Handle
- 10 Panel Mounted Keylock
- 11 Stored Energy Electrically Operated Mechanism
- 12 Mechanical Interlock Kit
- 13 Communication Module
- 14 Voltage Module
- 15 Display Module
- 16 External Neutral CT (with Adaptor Kit)

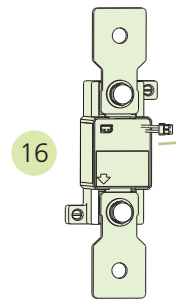
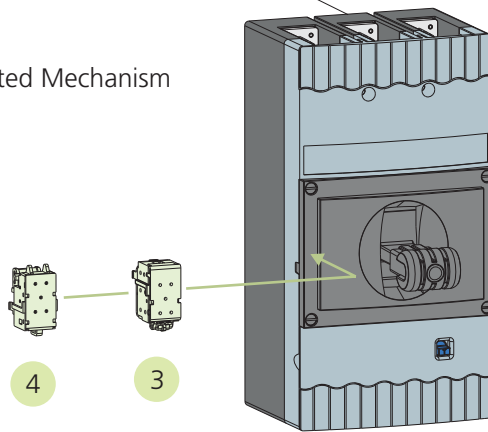
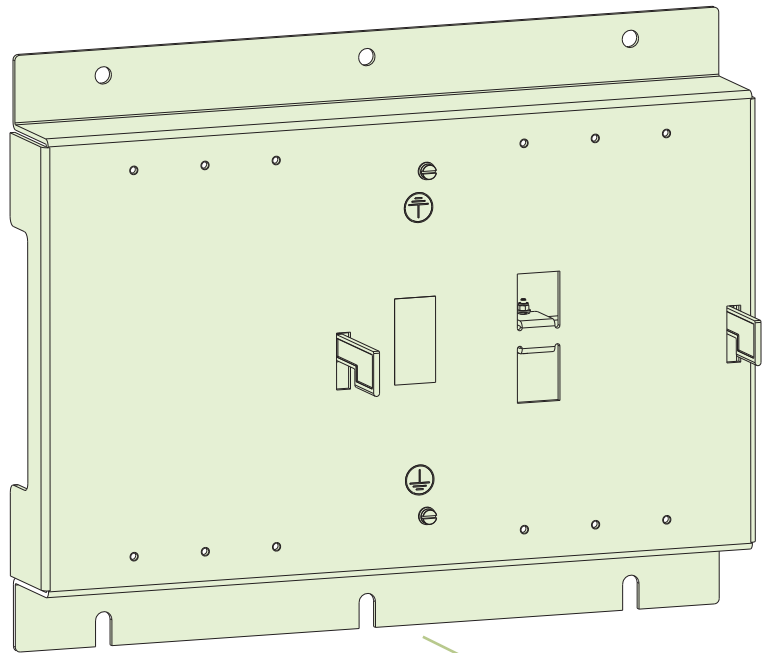

*** For Enclosure please refer page no. 50**

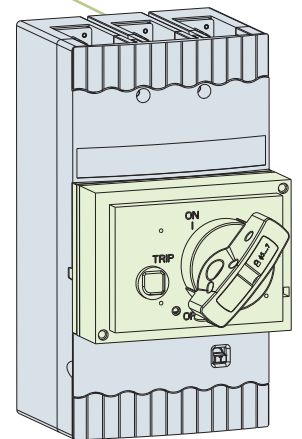
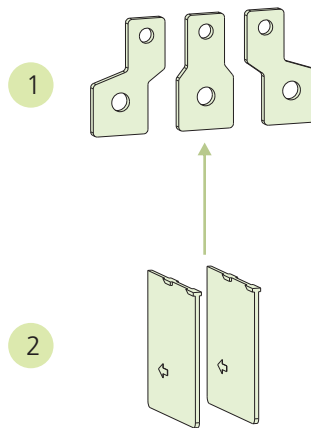

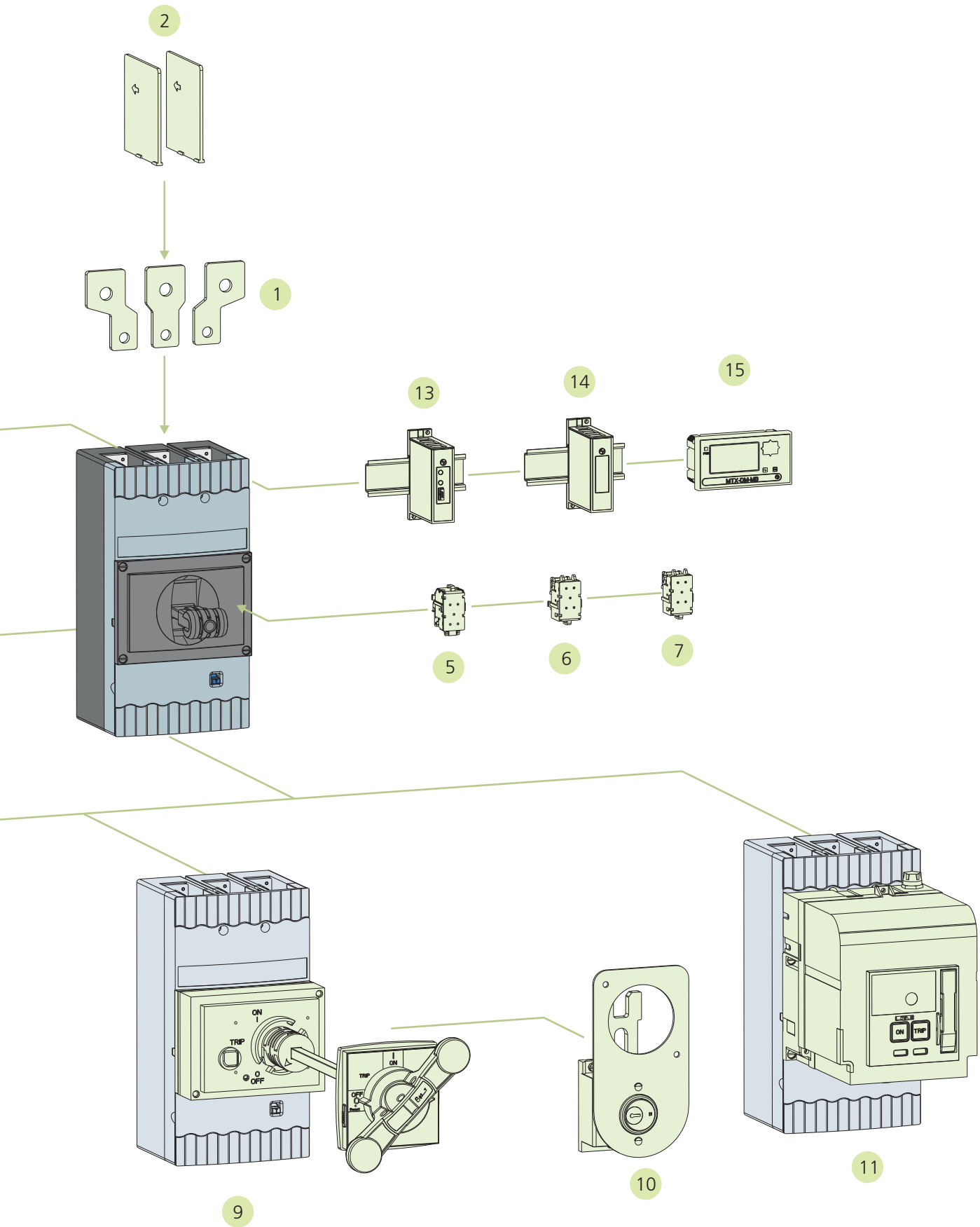



Product Data

- **MCCBs for Power Distribution** 26
 - Technical Datasheet
- **MCCBs for Motor & Isolator** 28
 - Motor Backup Protection
 - Isolator Application
- **MCCBs for DC & Capacitor Application** 29
 - DC Application
 - Capacitor Application
- **Protection Releases for MCCBs** 30
 - Thermal Magnetic Release
 - Microprocessor Release
- **MCCBs for Auto Source Transfer Application** 42
 - Auto Source Transfer Application

Technical Datasheet

Frame		100A		125A	250A		250A			
Type		DN0-100		DN0-125	DN1-250		DN2-250			
		C	D	D	C	N	D	N	S	
Release		TM		TM	TM		TM/MP (MTX1.0/2.0/3.0)			
Current Range I_n (A)		20, 25, 32, 40, 50, 63, 80, 100		125	125, 160, 200, 250		40, 63, 80, 100, 125, 160, 200, 250			
Poles		3/4		3/4	3/4		3/4			
Impulse withstand Voltage U_{imp} (kV)		8		8	8		8			
Rated Operational Voltage U_e (V) (MAX)		600		600	600		690			
Rated Insulation Voltage U_i (V)		800		800	800		800			
Utilization Category		A		A	A		A			
Standard										
Rated Short Circuit Breaking Capacity	I_{cu} (kA)	240 VAC	40	65	65	65	65	50	70	100
		415 VAC/440 VAC ^	25	36	36	25	50	36	50	70
		480 VAC/500 VAC	10	10	10	10	10	25	36	42
		550 VAC	8	8	8	8	8	18	25	36
		600 VAC	5	5	5	5	5	16	18	22
		690 VAC	-	-	-	-	-	10	15	20
	I_{cs} as % I_{cu}	240 VAC	100%	50%	50%	50%	50%	100%	100%	100%
		415 VAC/440 VAC	100%	50%	50%	100%	50%	100%	100%	100%
		480 VAC/500 VAC	100%	50%	50%	50%	50%	100%	100%	100%
		550 VAC	100%	50%	50%	50%	50%	100%	100%	100%
		600 VAC	100%	50%	50%	50%	50%	100%	100%	100%
		690 VAC	-	-	-	-	-	50%	50%	50%
Life	Mechanical	40000		40000	15000		25000			
	Electrical @1.0 I_n	12000	8000	4000	10000		10000			
Making Capacity (kA)		52.5	75.6	75.6	52.5	105	75.6	105	154	
Operating Frequency (Hz)										
Total Opening Time										
Finger-proof Terminals										
Suitable for Isolation										
IP class										
Pollution Degree										
Load Line Bias										
Ambient Temperature										
Storage Temperature										
Mounting Positions in Vertical Plane										
Dimensions (WxDxH) mm	3-Pole	75 x 60 x 130			105 x 60 x 165		105 x 96 x 179			
	4-Pole	100 x 60 x 130			140 x 60 x 165		140 x 96 x 179			
Weight (kg) (3/4 Pole)		0.8/1.1	0.73/1	0.73/1	1.55/2		2.5/3.3			
ACCESSORIES	INTERNAL	Auxiliary Contact								
		Trip Alarm Contact			1 C/O or 2 C/O					
		Auxiliary & Trip Alarm Contact								
		Shunt Release			240/415 V AC 50 Hz					
		Under Voltage Release								
	EXTERNAL	Rotary Operating Mechanism (Direct/Extended)			✓	✓			✓	
		Electrical Operating Mechanism			✗	✗			✓	
		Mechanical Interlock Kit			✗	✗			✓	
		Spreader Terminals			✓	✓			✓	
		Key lock			✓	✓			✓	
		Neutral CT with Adaptor kit			✗	✗				
		Current Metering Module			✗	✗				
Display, Communication and Voltage Module			✗	✗						

§ : 'NO' of control contactor to be connected in series for 220V DC, 24V DC

@ : Contains display module & metering module, separate cable required for connection

: Only Extended ROM available

^ : 440V AC reduce breaking capacity for DN0 & DN1

* : at 415V

DN2 - 1500 @ 690V

DN3 - 1000 @ 690V

DN4N - 800A - 2500 @ 415V

DN4S - 800A - 5000 @ 415V

		400A DN3B-400	400A DN3-400			630A DN3-630				1250A DN4-1250			
H	V		D	N	S	D	N	S	V	N	S	V	
	MP (MTX 1.0/2.0/3.0)	TM	TM/MP (MTX1.0/2.0/3.0)			TM/MP (MTX1.0/2.0/3.0)				MP (MTX1.0/2.0/3.0)			
	40, 63, 100, 160, 250	320, 400	320, 400			500, 630				400, 630	800, 1000, 1250		
		3/4	3/4			3/4					3/4		
		8	8			8					8		
		690	690			690					690		
		800	800			800					800		
		A	A			A					A		
IS/IEC60947-2, IEC60947-2 & EN60947-2													
100	100	50	50	70	100	50	70	100	100	70	100	100	
80	100	36	36	50	70	36	50	70	100	50	70	100	
65	65	25	25	36	42	25	36	42	65	25	36	65	
36	36	15	15	20	25	15	20	25	50	20	25	50	
22	36	12	12	18	22	12	18	22	50	16	20	50	
20	36	5	8	15	20	8	10	15	50	10	18	50	
100%	100%	100%	100%	100%	100%	100%	100%	100%	100%	100%	100%	100%	
100%	100%	100%	100%	100%	100%	100%	100%	100%	100%	100%	100%	100%	
100%	100%	100%	100%	100%	100%	100%	100%	100%	100%	100%	100%	100%	
100%	50%	100%	100%	100%	100%	100%	100%	100%	50%	100%	100%	50%	
100%	50%	100%	100%	100%	100%	100%	100%	100%	50%	100%	100%	50%	
50%	50%	50%	50%	50%	50%	50%	50%	50%	50%	50%	50%	50%	
	25000	10000	15000			15000			15000	20000			
	10000*	4000	4000			4000			4000*	3000*			
176	220	75.6	75.6	105	154	75.6	105	154	220	105	154	220	
50 / 60													
<10msec													
<20msec													
Yes													
Yes													
IP40													
III													
NO													
-5°C to 55°C													
-35°C to 70°C													
Vertical and 90 deg in both directions													
		140 x 111 x 205	140 x 111.5 x 266			140 x 111.5 x 266				210 x 143 x 370			
		184 x 111 x 205	183.5 x 111.5 x 266			183.5 x 111.5 x 266				278 x 143 x 370			
		4.0/5.0	5.5/7.2			6/7.8			6.3/8	17 / 22			
1 C/O or 2 C/O													
1 C/O													
1 C/O + 1 C/O													
110 / 415 V AC 50 Hz, 110 / 220 V DC, 24 V DC \$													
240 V AC 50 Hz													
✓													
✓#													
x													
x													
x													
x													
✓													
✓													
Available for 3P MCCBs with MTX2.0 & MTX3.0 release only													
Available for MTX2.0 release for current metering only @													
Available for MTX3.0 release for Communication & Power metering													

Note:

- Any two internal accessories can be mounted at a time
- V version MCCBs, to be used with extended ROM only
- Separate earth fault module required for earth fault protection using TM releases
- I_{cu} : Rated ultimate short-circuit breaking capacity
- I_{cs} : Rated service short-circuit breaking capacity
- Reference temperature 40°C & 50°C

Motor Backup Protection

AC induction motors are the vital elements in any production process and hence constitute majority of loads in Industry and other installations. The M version MCCBs in dsine range are developed specially to give short circuit protection for all types of motors. Selection of MCCB using our type 2 charts give reliable performance of the motors.



Frame		100A	160A	250A		400A	630A		
Type		DN0-100	DN1-160	DN2-250		DN3-400	DN3-630		
		M	M	M	MH	M	M	MV	
Current range (A)		32-100	100-160	100-250	63-250	320-400	500-630	320-630	
Poles		3	3	3	3	3	3	3	
Rated Short Circuit Breaking Capacity	I_{cu} (kA)	400 / 415 V	50	50	50	80	50	50	100
		480 V	10	10	36	65	36	36	65
		690 V	-	-	15	20	15	10	50
	I_q (kA)	415 V	50	50	50	80	50	50	100
		480 V	-	-	-	65	-	-	65
		690 V	-	-	100%	100%	100%	100%	50%
	I_{cs} as % I_{cu}	400 / 415 V	25%	50%	100%	100%	100%	100%	100%
		480 V	25%	50%	100%	100%	100%	100%	100%
		690 V	-	-	100%	100%	100%	100%	50%
Magnetic Setting		$9I_n$	$10I_n$			$10I_n$			

Note: MV version MCCBs to be used with extended ROM only.

Isolator Application

dsine MCCBs with Switch Disconnecter version offer solution for switching various loads such as UPS, Battery Banks etc. with various advantages. These MCCBs differ from regular MCCBs only in terms of absence of protection trip units. These MCCBs can be used for following applications for isolation purpose:

- For local isolation- such as very close to Motor load
- Generally used at the incoming of any sub-distribution
- As an Isolator for Bus coupler
- As an automatic switch
- For switching applications of motors with VFDs, soft starters

SD MCCBs are always backed up by the Short Circuit Protection Device (SCPD) to protect downstream loads/installations against short circuit. Our dsine SD MCCBs offer following advantages.

- Suitable for Positive isolation
- Available with 3P & 4P versions
- Can be used with Under Voltage Protection
- Remote tripping through Shunt release
- Motor operated MCCBs
- Status feedback possible

Following are the specifications of SD MCCBs



Frame	160A	250A	400A	400A	630A	800A	1000A	1250A
Type	DN0-160SD	DN2-250SD	DN3B-400SD	DN3-400SD	DN3-630SD	DN4-1250SD		
Current Range (A)	32-160	100-250	320-400	320-400	500-630	800	1000	1250
Poles	3/4	3/4	3/4	3/4	3/4	3/4	3/4	3/4
I_{cw} (kA)	2	3.6	5.5	5.5	7.6	10	12	15
Duration (sec)	1	1	1	1	1	1	0.5	0.1

Note: I_{cw} - Rated short-time withstand current

DC Application

DC power distribution is an upcoming technology in this modern era due to its most rigorous network power applications such as

- AC-DC Power System
- DC-DC Converter Systems
- DC-AC Inverter Systems
- DC UPS
- Batteries & Accessories
- Solution to alternative energy-Solar Power

We offer dsine MCCBs for the protection of DC systems in variety of current ratings from 20A-630A, voltage ratings upto 750V and various breaking capacities ranging from 5kA to 36kA.

Frame	DN0-125*		DN1-250		DN2-250			DN3-400			DN3B-400	DN3-630			
Type	C	D	C	N	D	N	S	D	N	S	D	D	N	S	
Release	TM														
Poles	3 or 4														
Rated current In (A)	20, 25, 32, 40, 50, 63, 80, 100, 125		125, 160, 200, 250		63, 80, 100, 125, 160, 200, 250			320, 400			320, 400		500, 630		
I _{cu} (kA rms)	250 V DC	20	20	20	30	36	20	30	36	25	20	30	36		
	500 V DC	15	15	15	20	25	15	20	25	10	15	20	25		
	750 V DC	-	-	10	15	20	10	15	20	-	10	15	20		
Type of connection	3P in series														
L/R (msec)	<15msec														

*Available only in DN0-125D

Switching of DC currents is much severe phenomenon than switching AC currents due to non occurrence of natural zero. Hence DC MCCBs are desired to give less breaking capacity than AC MCCBs for the same voltage & currents.

Note: Suitable for Thermal Magnetic release only

Capacitor Application

For any APFC panel, MCCBs are required for short circuit protection, overload protection and for isolation of capacitors. MCCB selection for capacitive load is tricky because of heavy inrush current, high overload capacity and continuous full load. These inherent traits of a capacitor, complicates the selection process. The selection should be such that the MCCB should not nuisance trip during inrush current and should withstand continuous flow of overload current.

Whenever we use MCCB in an APFC panel, proper measures need to be taken against the ill effects of the inrush current. Normally the inrush current (more than 100 times the rated capacitor current) will remain for a few micro-seconds and will not be sensed by the MCCB. However the contacts of MCCB may repel and bounce because of the current limiting feature, causing micro-arcs between the contacts of MCCB. This multiple bounce can result in premature failure of MCCB contacts. In order to reduce the magnitude of the peak inrush current, MCCBs must be used along with capacitor duty contactors or inrush current limiting reactors.

The maximum permissible current in a capacitor branch is 1.46 times the rated current. This factor is comprised of the following:

1. Harmonics overload and over voltage – 30%
2. Capacitance tolerance – 10%
3. Frequency variation – 2%

Hence adequate care needs to be taken while selecting switching & protection devices for capacitor applications. It is always advised to limit the switching inrush current within safe limits. For this, MCCB ratings should be chosen at least 1.5 to 2 times of capacitor rated current along with Capacitor Duty Contactors.

Thermal-Magnetic Release

Features of Thermal-Magnetic Release

- ➔ Adjustable overload settings
- ➔ Fixed / Adjustable short circuit settings
- ➔ True RMS sensing
- ➔ "Push to Trip" button



Protection	Settings		
	DN0 & DN1	DN2 & DN3	DN3B
Overload	80% - 100% I_n	80% - 100% I_n	80% - 100% I_n
Short Circuit	9 I_n (fixed)	6 - 10 I_n	9 I_n (fixed)
Earth fault	External GF Module required*		

Microprocessor Release

Features of MTX1.0

- ➔ Overload Protection with inverse time delay
- ➔ Adjustable Trip class
- ➔ Short Circuit Protection with selectable time delay
- ➔ Provision of Thermal memory defeat
- ➔ Provision for release testing
- ➔ Overload indication
- ➔ Power ON LED
- ➔ Self powered
- ➔ True RMS sensing
- ➔ "Push to Trip" button



MTX1.0	
Rated Current, I_n	From 40 to 1250A
Overload (Phase)	
Current setting, I_r ($I_r = x I_n$)	40% to 100% I_n in steps of 5%
Time delay, t_r (Inverse)	10s at 6 I_r , 3s at 6 I_r , 10s at 7.2 I_r , 3s at 7.2 I_r
Protection mode	ON / OFF
Thermal memory	Enable / Disable
Short Circuit	
Current setting, I_s ($I_s = x I_r$)	1.5, 2.5, 4.0, 5.5, 6.5, 8.0 I_r
Time delay, t_s	Instantaneous / 100ms
Protection mode	ON / OFF

Note: • Factory Settings - O/L: 100% I_n , Curves: 6 I_r @10s, Thermal Memory: Off, S/C: 5.5 I_r @ Instantaneous
 • Release provides in-built instantaneous override protection fixed @ 10 I_n

* Refer page 51

Microprocessor Release

Features of MTX2.0

- ➔ Overload Protection with inverse time delay
- ➔ Adjustable Trip class
- ➔ Short Circuit Protection with selectable time delay
- ➔ Inbuilt Earth fault and Neutral overload protection
- ➔ Provision of Thermal memory defeat
- ➔ Provision for release testing
- ➔ Overload indication
- ➔ Power ON LED
- ➔ Panel mounted O-LED display for current metering
- ➔ Self powered
- ➔ True RMS sensing
- ➔ "Push to Trip" button
- ➔ Latest trip record



MTX2.0	
Rated Current, I_n	From 40 to 1250A
Overload (Phase)	
Current setting, I_r ($I_r = x I_n$)	40% to 100% I_n in steps of 5%
Time delay, t_r (Inverse)	10s at $6I_r$, 3s at $6I_r$, 10s at $7.2I_r$, 3s at $7.2I_r$
Protection mode	ON / OFF
Thermal memory	Enable / Disable
Overload (Neutral)	
Current setting, I_N ($I_N = x I_r$)	50%, 100% and 150% I_r
Time delay, t_N	200ms / Same as overload
Protection mode	ON / OFF
Short Circuit	
Current setting, I_s ($I_s = x I_r$)	1.5, 2.5, 4.0, 5.5, 6.5, 8.0 I_r
Time delay, t_s	Instantaneous / 100ms
Protection mode	ON / OFF
Earth Fault	
Current setting, I_g ($I_g = x I_n$)	20% to 50% I_n in steps of 10%
Time delay, t_g	100ms / 200ms
Protection mode	ON / OFF

Note: • Factory Settings - O/L: 100% I_n , Curves: $6I_r @ 10s$, S/C: $5.5I_r @$ Instantaneous, Thermal Memory: Off, E/F: Off, Neutral: Off.
 • Release provides in-built instantaneous override protection fixed @ $10I_n$

Advanced features of MTX2.0

➔ Panel Mounted Display for Current Metering & Trip Record

System currents & latest trip record can be viewed with panel door closed.



➔ Port with Polarized Connector

MTX2.0 release with metering port is implemented with poka-yoke technology using polarized connector to ensure correct insertion of metering harness, thus avoiding unnecessary errors.

➔ Digital Current Metering

MTX releases are designed with protection class CTs which measure true RMS values. Inbuilt current metering does not require separate CTs hence maintenance is easy.

➔ O-LED Display

O-LED display allows the operator a wide viewing angle.

O-LEDs showing current metering has got faster response time and also consumes less power, hence saves energy. It has better contrast ratio as well.



Display Module



➔ **Inbuilt Earth Fault Protection** ————— 1

Inbuilt earth fault protection function does not require any separate trip coil & external CBCT, thus saving panel space, cost & improving the overall hygiene. Earth fault protection limits expenses by preventing damage to other equipment.

➔ **Thermal Memory** ————— 2

Thermal memory protects the system from thermal stresses generated by cumulative heating caused by cyclic overload conditions thus allowing the system to return to a safe operating temperature. This function also allows an optimization of cables or bus bar protection in case of low amplitude repetitive faults. Advance tripping increases the overall life and eliminates the production downtime incase of severe faults.

➔ **Multiple Trip Class** ————— 3

Enhances adjustability for better enhanced coordination with other devices to achieve correct motor switching and ensures protection of the starter elements in order to guarantee the plant safety.

➔ **Precise Selection of Parameters**

Overload & short circuit settings with minimum step change helps to maintain balance between nuisance tripping and optimal protection resulting in high continuity of service and reduced call back periods. MTX release can be adapted to specific requirements of OEM or end-user.

➔ **DIP Switches**

DIP switches are provided on front side of the release for easy operations. These switches give you quicker option to precisely change selection, offering high life.

➔ **Trip Indication** ————— 4

Improves uptime and productivity by setting alarms for unbalanced loads so that proactive measures can be taken to avoid overload conditions. Also, cause of fault (Short circuit and earth fault) can be indicated on the release as per below table.

% of I _n	Overload LED indication
80%	Slow blinking of green LED
115%	Faster blinking of green LED

Fault	LED Fault Indication	
	MTX1.0	MTX2.0/MTX3.0
Short Circuit	OFF-ON-OFF-ON-OFF-OFF-OFF-OFF	OFF-ON-OFF-ON-OFF-OFF-OFF-OFF
Earth Fault	—	ON-OFF-ON-OFF-ON-ON-ON-ON

Note: This sequence will continue till Aux Power is connected. One ON/OFF blink is of 0.5 sec.

➔ **Self Powered**

MTX releases do not need any external power supply hence require no extra devices and wires to power up.

The release power up with 30% loading with a power ON LED

Note: For wiring diagram, please refer page no. 62

Various Protection Settings

Overload Protection, ($I_r = x I_n$)



DIP Switch Position							
Setting	Bypass	40%	45%	50%	55%	60%	65%

DIP Switch Position							
Setting	70%	75%	80%	85%	90%	95%	100%

Thermal Memory

DIP Switch Position		
Setting	Bypass	ON

Overload Curves

DIP Switch Position				
Setting	3s @ 6 I_r	10s @ 6 I_r	3s @ 7.2 I_r	10s @ 7.2 I_r

Short Circuit Setting, ($I_s = x I_r$)

DIP Switch Position							
Setting	Bypass	1.5	2.5	4.0	5.5	6.5	8.0

Time Delay for Short Circuit Protection

DIP Switch Position		
Setting	Instantaneous	100ms

Earth Fault Setting, ($I_g = x I_n$)

DIP Switch Position					
Setting	Bypass	20%	30%	40%	50%

Time Delay for Earth Fault Protection

DIP Switch Position		
Setting	100ms	200ms

Neutral Setting, ($I_N = x I_l$)

DIP Switch Position				
Setting	Bypass	50%	100%	150%*

Time Delay for Neutral Protection

DIP Switch Position		
Setting	200ms	Follows O/L Curve

* With maximum overload setting $I_l=0.65I_n$

Microprocessor Release

Features of MTX3.0

- Overload Protection with inverse time delay
- I^2t , I^4t , SI, LI-VI based over load curves
- Short Circuit Protection with selectable time delay
- Instantaneous protection with fine settings
- Advanced current and voltage based protection function
- Protection against current unbalance and single phasing
- Comprehensive current, power and energy metering
- Inbuilt Earth fault and Neutral overload protection
- Provision of Thermal memory defeat
- Panel mounted O-LED display
- Communication through MODBUS RTU
- Pre-trip alarms
- True RMS sensing
- Power on LED
- "Push to Trip" button
- Self powered



MTX3.0	
Rated Current, I_n	From 40 to 1250A
Overload (Phase)	
Current setting, I_r ($I_r = x I_n$)	40% to 100% I_n in steps of 1% *
Time delay, t_r (Inverse)	0.5s to 30s in steps of 0.1s*
Protection mode	ON / OFF
Preset trip alarm setting	50% to 90% I_r in steps of 1% *
Thermal memory	Enable/Disable
Overload (Neutral)	
Current setting, I_N ($I_N = x I_r$)	50% to 150% I_r in steps of 1% *
Time delay, t_N	0.2s / same as overload*
Protection mode	ON / OFF
Short Circuit	
Current setting, I_s ($I_s = x I_r$)	1.5 to 8 I_r in steps of 0.1 *
Time delay, t_s	100ms, 200ms, 300ms, 400ms*
Protection mode	ON / OFF
Preset trip alarm setting	50% to 90% I_s in steps of 1% *
Instantaneous	
Current setting, I_i ($I_i = x I_n$)	1.5 to 8 I_n in steps of 0.1 *
Protection mode	ON / OFF
Preset trip alarm setting	50% to 90% I_i in steps of 1% *
Earth Fault	
Current setting, I_g ($I_g = x I_n$)	10%* to 50% I_n in steps of 5%*
Time delay, t_g	100ms to 500ms in steps of 50ms*
Protection mode	ON / OFF

* Can be set using communication and display module

Note: • Factory Settings - Address:0000, O/L: 100% I_n , Curves: 6I_r@10s, S/C: 5.5I_r @ Instantaneous, Thermal Memory: Off, E/F: Off, Neutral: Off.

- Release provides in-built instantaneous override protection fixed @ 10 I_n

MTX3.0 Additional features with Display Module

Current Protection	
Under Current	
Current setting (A) $I_{ui} (I_{ui} = x I_r)$	20 to 85% I_r in steps of 1%
Time delay (s)	1 to 255 in steps of 1
Protection mode	ON / OFF
Preset trip alarm setting	110% to 150% I_{ui} in steps of 1%
Current Unbalance	
Current setting (A)	30 to 90% I_r in steps of 1%
Time delay (s)	0.5 to 60 in steps of 0.1
Protection mode	ON / OFF
Preset trip alarm setting	50 to 90% of set value in steps of 1%

Voltage Protection	
Under Voltage	
Voltage setting (V) $V_{uv} (V_{uv} = x U_n)$	45 to 80% U_n in steps of 1%
Time delay (s)	0.5 to 60 in steps of 0.1
Protection mode	ON / OFF
Preset trip alarm setting	110 to 150% V_{uv} in steps of 1%
Over Voltage	
Voltage setting (V) $V_{ov} (V_{ov} = x U_n)$	105 to 150% U_n in steps of 1%
Time delay (s)	0.5 to 60 in steps of 0.1
Protection mode	ON / OFF
Preset trip alarm setting	50 to 90% V_{ov} in steps of 1%
Voltage Unbalance	
Voltage setting (V)	5 to 20% U_n in steps of 1%
Time delay (s)	0.5 to 60 in steps of 0.1
Protection mode	ON / OFF
Preset trip alarm setting	50 to 90% of set value in steps of 1%
Residual Voltage	
Voltage setting (V)	5 to 40% U_n in steps of 1%
Time delay (s)	0.5 to 60 in steps of 0.1
Protection mode	ON / OFF
Preset trip alarm setting	50 to 90% of set value in steps of 1%

Frequency Protection	
Under Frequency	
Frequency setting (Hz)	F-0.5 to F-5.0 in steps of 0.5
Time delay (s)	0.1 to 30 in steps of 0.1
Protection mode	ON / OFF
Preset trip alarm setting	50 to 90% of set freq in steps of 1%
Over Frequency	
Frequency setting (Hz)	F+0.5 to F+5.0 in steps of 0.5
Time delay (s)	0.1 to 30 in steps of 0.1
Protection mode	ON / OFF
Preset trip alarm setting	50 to 90% of set freq in steps of 1%

Power Protection	
Reverse Power	
Power setting (W) P_R	1 to 5000kW in steps of 1kW
Time delay (s)	0.5 to 60 in steps of 0.5
Protection mode	ON / OFF
Preset trip alarm setting	50 to 90% P_R in steps of 1%
Lead Pf	
Pf setting	0.5 to 0.99 in steps of 1%
Time delay (ms)	100 to 500 in steps of 1
Protection mode	ON / OFF
Preset trip alarm setting	50 to 90% of set value in steps of 1%
Lag Pf	
Pf setting	0.5 to 0.99 in steps of 1%
Time delay (ms)	100 to 500 in steps of 1
Protection mode	ON / OFF
Preset trip alarm setting	50 to 90% of set value in steps of 1%

Other Protections	
MD Active	
Demand settings	1 to 5000kW in steps of 1kW
Protection mode	ON / OFF
Preset trip alarm setting	50 to 90% of set value in steps of 1%
MD Reactive	
Demand settings	1 to 5000kVAr in steps of 1kVAr
Protection mode	ON / OFF
Preset trip alarm setting	50 to 90% of set value in steps of 1%
MD Apparent	
Demand settings	1 to 5000kVA in steps of 1kVA
Protection mode	ON / OFF
Preset trip alarm setting	50 to 90% of set value in steps of 1%
Phase Sequence	
Phase seq setting	123 or 132
Time delay (s)	1 to 5 in steps of 0.1
Protection mode	ON / OFF
THD Current	
Current setting (A)	5 to 50% I_r in steps of 1%
Time delay (s)	5 to 15 in steps of 5
Protection mode	ON / OFF
Preset trip alarm setting	50 to 90% of set value in steps of 1%
THD Voltage	
Voltage setting (V)	5 to 50% U_n in steps of 1%
Time delay (s)	5 to 15 in steps of 0.1
Protection mode	ON / OFF
Preset trip alarm setting	50 to 90% of set value in steps of 1%

Metering & Display	
Current	Phase, Neutral & Earth
Voltage	Phase & Line
Frequency & power factor	True RMS
Power	Active, Reactive & Apparent
Energy	Active, Reactive & Apparent
Maximum demand	Active, Reactive & Apparent
THD	Current and voltage
Communication	
Protocol	MODBUS RTU
History	
Trip history	Last 10 trip records with non volatile memory
Event history	Last 10 event records with non volatile memory

Advanced Features of MTX3.0

Energy & Power Measurement

- One of the first steps towards energy efficiency is energy and power measurement. In MTX 3.0 release, in addition to current & voltage measurement, active, reactive and apparent energy & power can also be measured. This would enable monitoring energy at individual feeder level and thus help in implementing effective energy management practices in the plant. Moreover, using communication module, different parameters reading can be viewed on display module.



Energy and Power management functionality using voltage module

➔ Advanced Current and Voltage based protections

- **Reverse Phase:**

This function detects the phase reversal of current from the set sequence. It is especially important in motor feeder applications

- **Reverse Power:**

One can set the direction of power flow in a system from source to load and in case the direction of power flow reverses, the reverse power protection can be activated to trip the system. This is especially important in a DG set or in a ring mains system.



➔ Power Quality Control

MTX3.0 release measures the frequency, power factor and offers protection against leading and lagging values thereby assisting in maintaining the power quality. This release measures THD of current & voltage and gives an alarm / trip in case it exceeds the set thresholds.



➔ Communication Capable

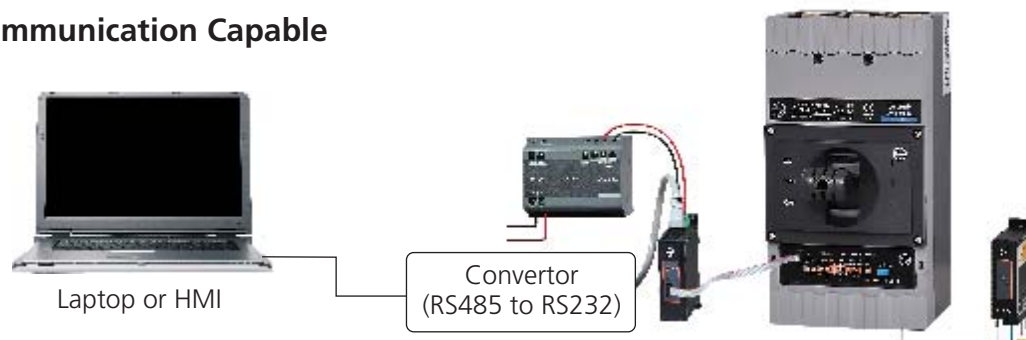

Most advanced release of MTX series, MTX3.0 is communication capable on MODBUS RTU network. Using MODBUS com module the MCCB release can be connected to a Personal Computer. The metering values can be read remotely. The settings configuration on the other hand can both be read and changed remotely. These releases are also made compatible with HMI (Human Machine Interface) & DCS (Data Control Systems)

➔ Multi-looping

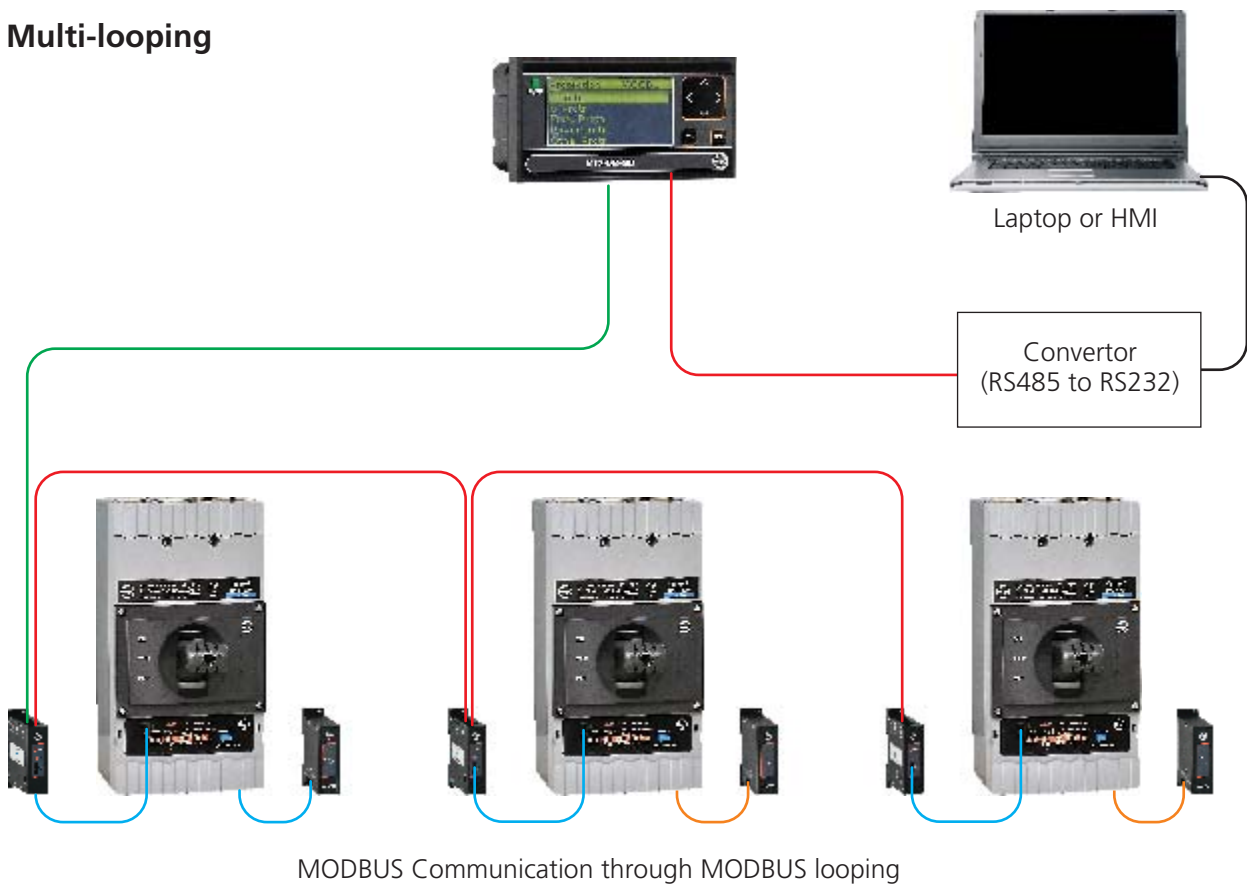

A single display module can be used to connect upto 15 MCCBs with MTX3.0 release through MODBUS network. Highly reliable data yet extremely simple looping reduces operational headaches and enhances remote accessibility.

➔ Maintenance Functionality

MTX3.0 release can store last 10 trip records & last 10 event records which can be used for the system analysis later on. These recorded values can be viewed from display unit as well as PC.

Note: For wiring diagram, please refer page no. 63

AuXC-2000 Controller

There are many electrical services which are required to be powered up always. Interruption of supply to these kinds of services is not desired. These loads are part of any industry, hospital, school, commercial buildings, shopping malls, name any place of importance. These loads can be firefighting system, emergency lighting, control stations, CCTV, emergency pumps, security system etc. L&T's micro-processor based Automatic Transfer Controller AuXC-2000 along with L&T switchgear is the answer to all auto source transfer requirements.



Changeover Conditions

All the conditions which can help establish whether a power source is or is not suitable are defined by the user through setting following parameters

Parameter	Description
Minimum voltage	One or more phases too low
Maximum voltage	One or more phases too high
Phase loss	Threshold below which the unit intervention is quicker than with a normal decrease.
Asymmetry (unbalance)	Phases within the Maximum-Minimum range but too different from each other
Minimum frequency	Too low frequency
Maximum frequency	Too high frequency
Phase sequence	Reverse rotation of phases

Intuitive user interface

- 5 keys membrane keypad for parameters setting.
- 128x80 pixel, Backlight LCD screen with 4 Grey levels.

Status at a glance

- 4 LEDs for plant synoptic (source line and breakers status).
- 2 LEDs for alarm presence and AUTO mode active.

Flexibility to suit side conditions

- Suitable for switching between Utility-Utility or Utility-Genset or Genset-Genset
- Selectability between auto and manual mode of switching
- Enabling and disabling of priority supply.
- Settable transition time for all events
- Selectability between Open before presence of secondary supply (OBP) & open after presence of secondary supply (OAP) available

Programmable digital inputs, outputs & alarms to control changeover device

- 6 programmable digital inputs (negative).
- 6 + 1 digital outputs:
 - 6 relays with NO contact 8A 250VAC
 - 1 relays with changeover contact 8A 250VAC
- 18 alarms (4 user programmable alarms)

Password access to prevent any unauthorized access

- The password is used to enable or lock the access to setting menu and to commands menu.

Generator setup

- Management of generator set start-stop & cooling cycle
- Management of automatic test for generators with emergency and rotation.

Failure simulation

- Test the changeover setup without connecting actual load

EJP (Effacement Jours Pointe) function

- Switch from the main supply to standby power for the duration of a tariff period with higher prices.

Event Logger

- Storage of last 100 events.

AC Supply : terminals 13, 14	
Rated voltage Us	100 - 240V~
Operating voltage range	90 -264V~ 93.5 - 300V=
Frequency	45 - 66Hz
Power consumption/dissipation	3.8W - 9.5VA
Immunity time for microbreakings	≤ 50ms (110V~) ≤ 250ms (220V~)
Recommended fuses	F1A (fast)
Insulation voltage	
AC Supply	
Rated insulation voltage	Ui 250V~
Rated impulse withstand voltage	Uimp 6kV
Power frequency withstand voltage	3kV
Line 1 and Line 2 voltage inputs	
Rated insulation voltage	Ui 480V~
Rated impulse withstand voltage	Uimp 6kV
Power frequency withstand voltage	3.8kV
OUT1 and OUT 2 outputs	
Insulation type	Single between OUT1 and OUT 2 Double toward the remaining groups
Rated insulation voltage	Ui 250V~
	Single Double
Rated impulse withstand voltage	Uimp 4kV Uimp 6kV
Power frequency withstand voltage	1.5kV 3kV
OUT 3 output	
Rated insulation voltage	Ui 250V~
Rated impulse withstand voltage	Uimp 6kV
Power frequency withstand voltage	3kV
OUT4-5 and OUT 6-7 outputs	
Insulation type	Single between OUT4-5 and OUT 6-7 Double toward the remaining groups
Rated insulation voltage	Ui 250V~
	Single Double
Rated impulse withstand voltage	Uimp 4kV Uimp 6kV
Power frequency withstand voltage	1.5kV 3kV
Line 1 and Line 2 voltage inputs: terminals 1-4 and 5-8	
Maximum rated voltage Ue	100...480V~ L-L (277VAC L-N)
Measuring range	50...576V~ L-L (333V~L-N)
Frequency range	45-65Hz
Measuring method	True RMS
Measuring input impedance	> 0.5MW L-N > 1,0MW L-L
Wiring mode	Single-phase, two-phase, three-phase with or without neutral or balanced three-phase system.
Ambient operating conditions	
Operating temperature +70°C	-30.....
Vibration resistance	-30... +80°C
Climatic sequence	<80% (IEC/EN 60068-2-78)
Shock resistance	2
Measurement category	3
Overvoltage category	III
Maximum pollution degree	Z/ABDM (IEC/EN 60068-2-61)
Relative humidity	15g (IEC/EN 60068-2-27)
Storage temperature	0.7g (IEC/EN 60068-2-6)

Measuring accuracy	
Mains and generator voltage	±0.25% f.s. ±1digit
Real time clock	
Energy storage	Back-up capacitors
Operating time without supply voltage	About 5 minutes
Digital inputs: terminals 15 - 20	
Input type	Negative
Current input	≤8mA
Input "low" voltage	≤2,2
Input "high" voltage	≥3,4
Input delay	≥50ms
OUT1 and OUT 2 outputs: terminals 9,10 e 11,12	
Contact type	2 x 1 NO
Rated current	AC1 - 8A 250V~ DC1 - 8A 30V= AC15 -1.5A 250V~
Max rated voltage	300V~
Mechanical / electrical endurance	1x10 ⁷ / 1x10 ⁵ ops
OUT3 output: terminals 22, 23, 24	
Contact type	1 changeover
Rated current	AC1 - 8A 250V~ DC1 - 8A 30V= AC15 -1.5A 250V~
Max rated voltage	300V~
Mechanical / electrical endurance	1x10 ⁷ / 1x10 ⁵ ops
OUT4 and OUT 5 outputs: terminals 25,26,27	
Contact type	2 x 1 NO + contact common
Rated current	AC1 - 8A 250V~ DC1 - 8A 30V= AC15 -1.5A 250V~
Max rated voltage	300V~
Mechanical / electrical endurance	1x10 ⁷ / 1x10 ⁵ ops
Maximum current at contact common	10A
OUT6 and OUT 7 outputs: terminals 28,29,30	
Contact type	2 x 1 NO + contact common
Rated current	AC1 - 8A 250V~ DC1 - 8A 30V= AC15 -1.5A 250V~
Max rated voltage	300V~
Mechanical / electrical endurance	1x10 ⁷ / 1x10 ⁵ ops
Maximum current at contact common	10A
Connections	
Terminal type	Plug-in / removable
Cable cross section (min... max)	0.2-2.5 mm ² (24... 12 AWG)
Tightening torque	0.56 Nm (5 lbin)
Housing	
Version	Flushmount
Material	Polycarbonate
Degree of protection	IP40 on front / IP20 terminals
Weight	680g

*Notice: this product has been designed for environment A. Use of this product in environment B may cause unwanted electromagnetic disturbances in which case the user may be required to take adequate mitigation measures.



Accessories

■ Internal Accessories

46

- Auxiliary Contact
- Trip Alarm Contact
- Auxiliary Trip Alarm Contact
- Shunt Release
- Under Voltage Release

■ External Accessories

47

- Rotary Operating Mechanism
- Mechanical Interlocking Kit
- Keylock
- Spreader Terminals
- External Neutral CT
- Stored Energy Electrically Operated Mechanism
- MTX Modules
- MCCB Enclosure
- Earth Fault Module

Internal Accessories



MCCB with mid cover opened & Internal accessories fitted

dsine range of MCCBs are offered with snap-fit type, easily installable internal accessories. There is no need to open main cover and no live parts are accessed during installation. TAC, Aux+TAC to be fitted in the right cavity & under voltage release to be fitted in left cavity.

Double Insulation: The internal accessories are housed in insulated casings to ensure first level of insulation. When the front cover is opened for the fixing of internal accessories, the MCCB is totally insulated ensuring the double insulation.



Auxiliary Contact



TAC



Shunt Release



UV Release

Internal Accessories	Contacts/Supply Voltage	Frame	Cavity
Auxiliary Contact	1 C/O	DN0, DN1	Right
		DN2, DN3, DN3B, DN4	Right/Left
	2 C/O	DN0, DN1	Right
		DN2, DN3, DN3B, DN4	Right/Left
Trip Alarm Contact	1 C/O	DN0, DN1	Right
		DN2, DN3, DN3B, DN4	Right
	2 C/O	DN0, DN1	Right
Auxiliary + Trip Alarm Contact	1 C/O + 1 C/O	DN0, DN1	Right
		DN2, DN3, DN3B, DN4	Right
Shunt Release	240/415V AC 50Hz	DN0, DN1	Left
	110/415V AC 50Hz, 110/220V, 24V DC	DN2, DN3, DN3B, DN4	Right/Left
Under Voltage Release	240V AC	DN0, DN1	Left
		DN2, DN3, DN3B	
		DN4	

Shunt Release

It allows opening of MCCB by means of an electrical command. Operation of the release is guaranteed for a voltage between 70% and 110% of the rated power supply voltage value U_e , both in AC & DC.

Frame	Operational Voltage	Power Consumption
DN0 / DN1	240 / 415V AC, 50Hz	1500VA
DN2 / DN3 / DN3B / DN4	110 - 415V AC, 50Hz	1500VA
	110 / 220V DC	85W
	24V DC	10W

UV Release

The Under-voltage release causes the MCCB to trip if the operational voltage falls to a value between 35% and 70% of its rated voltage or not applied. UV release mechanically locks the closing mechanism of MCCB & makes it impossible to close on under-voltage or no voltage, both manually & electrically. With the under-voltage release de-energized, it is not possible to close the MCCB. UV release can also be used for interlocking schemes (for DG synchronization, paralleling of transformers etc) also.

Frame	Operational Voltage	Power consumption
DN0 / DN1	240V AC, 50Hz	5VA
DN2 / DN3 / DN3B	240V AC, 50Hz	5VA
DN4	240V AC, 50Hz	5VA

External Accessories

Rotary Operating Mechanism

Rotary operating mechanism (ROM) for dsine MCCBs are available in direct & extended versions.

1. Direct Rotary Handle (MCCB mounted)

- Available for entire family of dsine MCCBs
- In built pad locking feature



Direct Rotary Handle (MCCB mounted)

2. Extended Rotary Handle (Panel Mounted)

- ROM mounts directly on MCCB without removal of mid cover
- Clear ON/OFF/TRIP indication
- Clear view of MCCB rating label
- Direct access to "Push to Trip" button
- IP 54 degree of protection with extended rotary handle
- Unique coupling to allow ± 3 mm tolerance
- Door interlock in ON position, with defeat facility
- Door interlock in OFF condition with padlock feature
- Auto restoration of door interlock
- External keylock for mechanical interlocking



Extended Rotary Handle: Panel Mounted



Panel Door Mounted Key lock (To be used along with Extended Rotary Handles)

Mechanical Interlocking Schemes

1. Mechanical Interlocking Kit:

Two MCCBs can be interlocked using base plate mechanism, in side-by-side configuration.

➔ Features

- For 3P & 4P versions
- For DN2 & Dn3 frames
- Site fittable



MIL with Base Plate

2. Mechanical Interlocking using Key Locks:

For mechanical interlocking through extended rotary operating mechanism, a panel mounted key lock is available. The selection of the key lock as per the table:

I/C or B/C	Key Lock
2 I/C	Any 1 type of lock for both MCCBs
2 I/C and 1 B/C	Lock 1 and Lock 2 for I/C and Lock 12 for B/C
3 I/C and 2 B/C	Locks 1, 2, 3 for I/Cs and Locks 12, 23 for B/Cs

Key Lock Selection:

Type of lock	Exclusively operable by key nos.
1	1
2	2
3	3
12	1, 2 & 12
23	2, 3 & 23

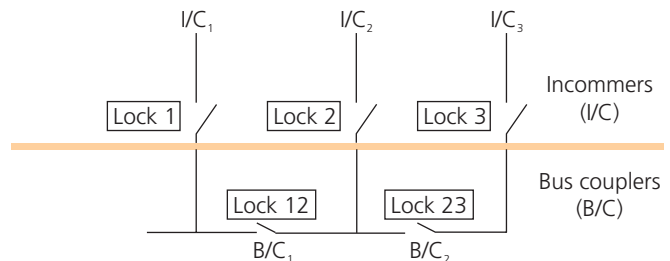

Spreader Terminal

- Available for enhancing termination capacity
- Made of silver plated copper



Terminal capacity without spreader terminals

Rating (A)	16-100		125-250		320-630		800-1250	
dsine Frame	Cable (mm ²)	Link(mm)	Cable (mm ²)	Link(mm)	Cable (mm ²)	Link(mm)	Cable (mm ²)	Link(mm)
DN0	35	17						
DN1			120	26				
DN2			95	25				
DN3					120	27 ^s		
DN3B*					185	32		
DN4							-	2 x 40

\$ 30mm on request

Terminal capacity with spreader terminals

Rating (A)	16-100		125-250		320-630		800-1250	
dsine Frame	Cable (mm ²)	Link (mm)	Cable (mm ²)	Link (mm)	Cable (mm ²)	Link (mm)	Cable (mm ²)	Link (mm)
DN0	50	22						
DN1			185	35				
DN2			185	35				
DN3					2 x 240	2 x 40		
DN3B*					2 x 240	2 x 40		
DN4							2 x 300	2 x 60

* DN3B available in 320A and 400A only

Note: Phase barriers are supplied along with MCCBs ; Copper termination recommended for enhanced performance

External Neutral CTs

- Used to provide neutral & earth fault protection to 3P MCCBs in 3 phase 4 wire system
- Available for 3P MCCBs with MTX2.0 & 3.0 releases
- Adapters for NCT available



Stored Energy Electrically Operated Mechanism

- ON / OFF & Charged/Discharged indication
- Foolproof mounting
- Selector switch for Auto/Manual operation
- Padlock facility for locking in OFF position (3 nos. locks)
- Higher mechanical & electrical endurance
- Back up fuse for extended motor protection
- Easy access to the protection setting on MCCB
- True indication for ON/OFF & Trip



Specification	DN2	DN3
Operating voltage (V AC)	240V AC	240V AC
Operating voltage (%)	85-110%	85-110%
Closing time (ms)	60	90
Opening time (ms)	300	450
Power consumption (VA)	350	500
Life / No. of operations	16000	15000
Door cut out (mm ²)	96 x 96	96 x 96
IP protection, on the front	IP30	IP30
Operating frequency	2/min	1/min
Min. control impulse time (ms)*	800	800



Note: For wiring diagram, please refer page no. 62
 * At rated voltage

Power Supply (PS) Module

PS module is used to power ON dsine MTX modules when auxiliary 24Vdc supply is not available.

Specifications	AC	DC
Input	85-265V	125-300V
Output 1 [#]	-	200mA at 24V DC
Output 2	-	650mA at 24V DC

[#] For using Output 1, Output 2 should be loaded



➔ Current Metering Module for MTX2.0

It consists of 2 parts viz. Metering module & Display module. Metering module collects the data from the release and sends the same to the Display module. The panel mounted O-LED Display module shows various parameters viz. 3 phase currents, neutral and ground fault currents, if any. We can also view last trip records.

➔ Communication Module for MTX3.0

The Communication module is solution for connecting dsine MCCBs to Modbus network for remote supervision and control of circuit breaker. It is suitable for the MTX3.0 electronic trip units across DN2/DN3/DN4 frames. It is available with DIN rail mounting facility. 2 LEDs in front of the module indicates

- The Power LED - the presence of auxiliary power supply to the module
- The Data LED - transmission of data

Its operating temperature is -25°C to 70°C and consumption is 43mA



➔ Voltage Module for MTX3.0

This accessory when connected to MTX 3.0 release in DN2/DN3/DN4 frames is able to provide the various measurements of the electrical values of the plant like voltage, power, energy & frequency . It can be mounted just beside the MCCB on a DIN plate. Its operating temperature is -25°C to 70°C



➔ Display Module for MTX3.0

It is a panel mounted O-LED display unit that can be integrated with MTX3.0 release . It has one navigation key, a select button & an exit button. Provision for taking D+, D- from this module is also provided. You can simultaneously view parameters remotely & on display. Its operating temperature is -25°C to 70°C and consumption is 12mA

The module displays wide range of parameters as follows

- Phase current, ground current, earth leakage current
- Phase / Line voltage
- Active / Reactive / Apparent Power
- Power factor, Frequency
- Energy
- Maximum demand
- THD



➔ MTX Test Kit

- Universal Test Kit for all MTX releases
- Simulation of overload, short-circuit & earth fault
- Single phase AC supply

➔ MCCB Enclosure

New Range of MCCB enclosures, Size I suitable for DN0 frame and Size II for DN1 frame. These standalone enclosures not only provides ample space for cable termination but are also superior in aesthetics.

- Conforms to IEC 62208, IEC 62262 and IEC 60529
- Common Enclosure for 3P/4P MCCBs
- RoHS compliant
- IP30 Protection & IK08 Protection
- Inbuilt Neutral Link for TPN systems
- Mounting Holes on the back plate
- Louvers for better heat dissipation



Enclosure	Height (mm)	Width (mm)	Depth (mm)
Size I	543	198	97
Size II	830	337	111.2

Note: For wiring diagram of modules, please refer page no. 63

Earth Fault Module

Earth Fault Modules Type GF1, GF2 and GF11. These modules are to be used with MCCBs for earth fault protection. The principle of operation is based on detection of the residual current in the system. They combine safety and versatility, conforming to the high performance standards, the characteristic of all L&T products.



Earth Fault Module GF1
GF1 is suitable upto 200A MCCBs



Earth Fault Module GF2
GF2 is suitable upto 200A-400A MCCBs



Earth Fault Module GF11
GF11 is suitable upto 800A MCCBs

Features:

- Compact in size
- Solid state design
- Built-in moulded CBCT for GF1 & GF2. External CTs are to be used for GF11
- Suitable for both 3 phase 3 wire & 3 Phase 4 wire systems. In case of 3 phase 4 wire system, the neutral cable/twisted link should also be passed through the CBCT along with the 3 phase links / cables
- Built-in test facility
- Selection facility for nominal current rating (I_n)
- Earth fault setting is adjustable from 10% to 50% of set current
- Selectable trip times (100 ms, 200 ms)
- Manual reset for positive fault acknowledgment
- Potential free NO contact to trip MCCB (through 240 V shunt release)
- Window dimensions suitable for Cable connection only in GF1 and GF2

Note: MCCBs need to be fitted with 110 V / 240 V AC shunt release for Earth Fault Module operation.

Technical Data

Specification	Type GF1 / GF2 / GF11
Current Setting Range, I_s ($I_s = x I_n$)	10% to 50% I_n in steps of 10%
Auxiliary Supply	240V AC $\pm 20\%$
Time Delay (ms)	100 / 200ms Field selectable
Pick-up Accuracy	$\pm 10\% I_s$
Output Contact	1 NO contact manual reset Type contact rating 5A 240V AC
Indication	a) Power On LED b) Trip LED (manual reset)
Operating Temperature	+10°C to +55°C
Insulation	2 kV 50Hz for one minute across independent circuit 1 kV 50Hz for one minute across open contacts
Mounting	Base plate mounting type
Window for Cable / Busbar entry (mm ²)	GF1 - 110 x 32 GF2 - 165 x 61.5
Weight (kg)	GF1 - 1.2, GF2 - 2.2, GF11 - 0.9

Note: For wiring diagram, please refer page no. 61

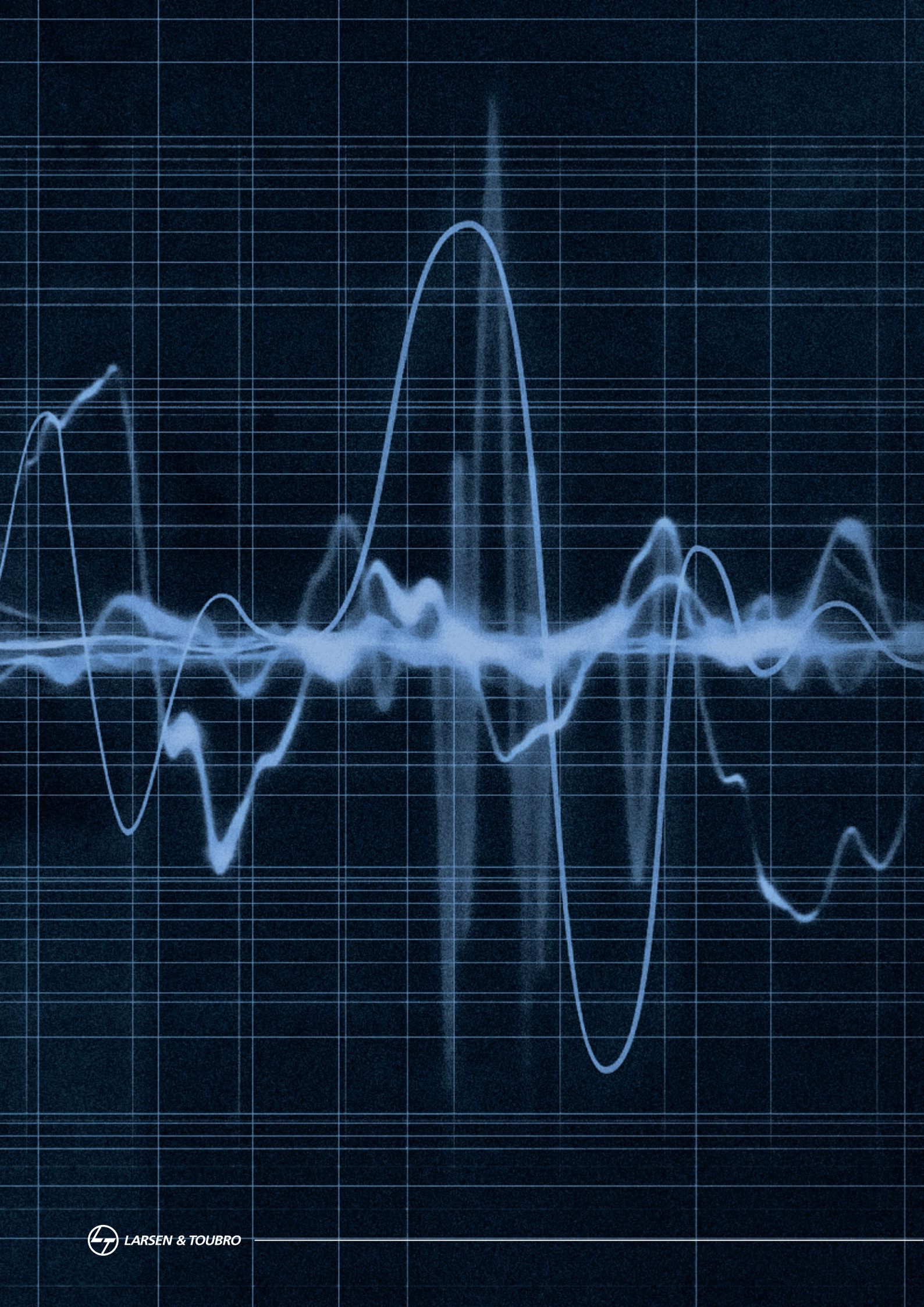

Characteristic Curves

■ Thermal Magnetic Release

54

- ▶ DN0
- ▶ DN1
- ▶ DN2
- ▶ DN3B
- ▶ DN3

■ Microprocessor Release

55

- ▶ MTX1.0-2.0 (O/L curves)
 - I^2T at $6I_r$, $7.2I_r$
- ▶ MTX3.0 (O/L curves)
 - I^2T at $1.5I_r$, $6I_r$, $7.2I_r$
 - I^4T at $1.5I_r$, $6I_r$, $7.2I_r$
 - SI at $1.5I_r$, $6I_r$, $7.2I_r$
 - LI-VI at $1.5I_r$, $6I_r$, $7.2I_r$
 - Short circuit, Earth fault & Neutral curves For MTX1.0-2.0-3.0

Thermal-Magnetic Release



DN0 MCCB

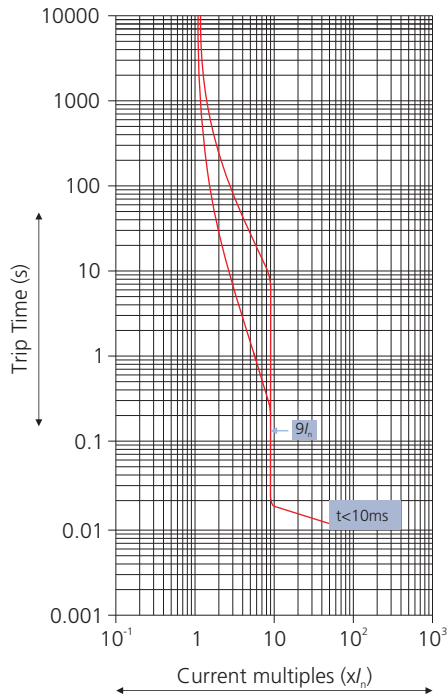

DN1 MCCB

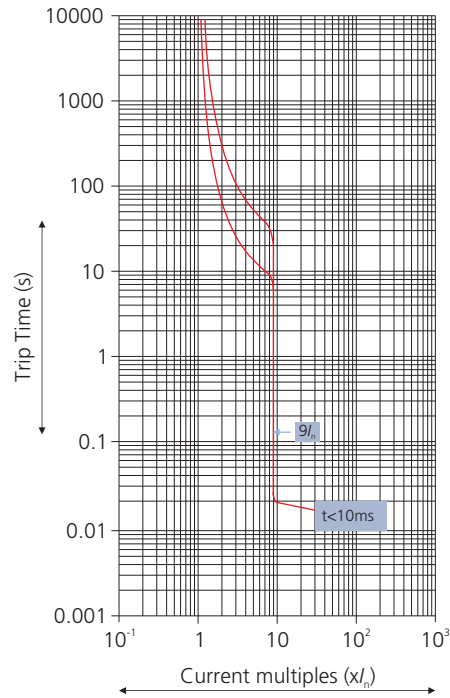

DN2 MCCB

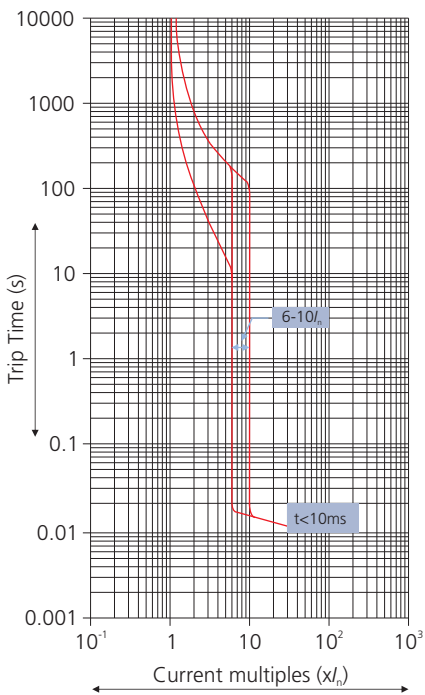

DN3B MCCB

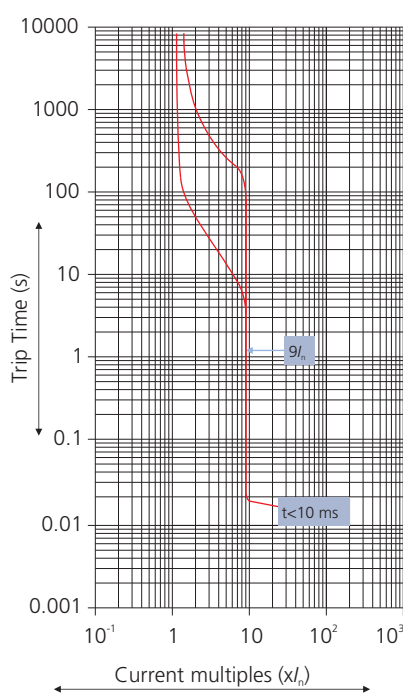

DN3 MCCB

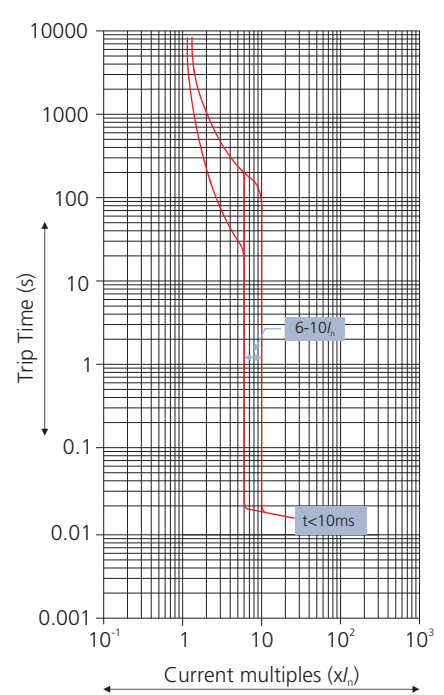

Note: Curves are Ir based till overload zone.

Microprocessor Release



MTX1.0 / 2.0 - DN2 / DN3 / DN4 (O/L curves - I^2t)

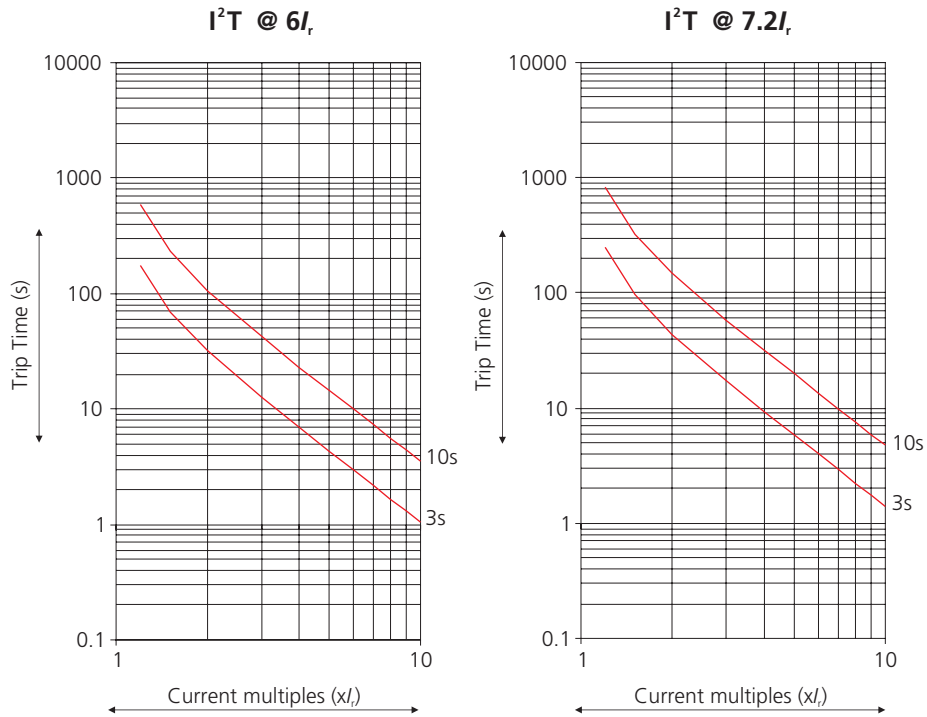

MTX3.0 - DN2 / DN3 / DN4 (O/L curves - I^2t)

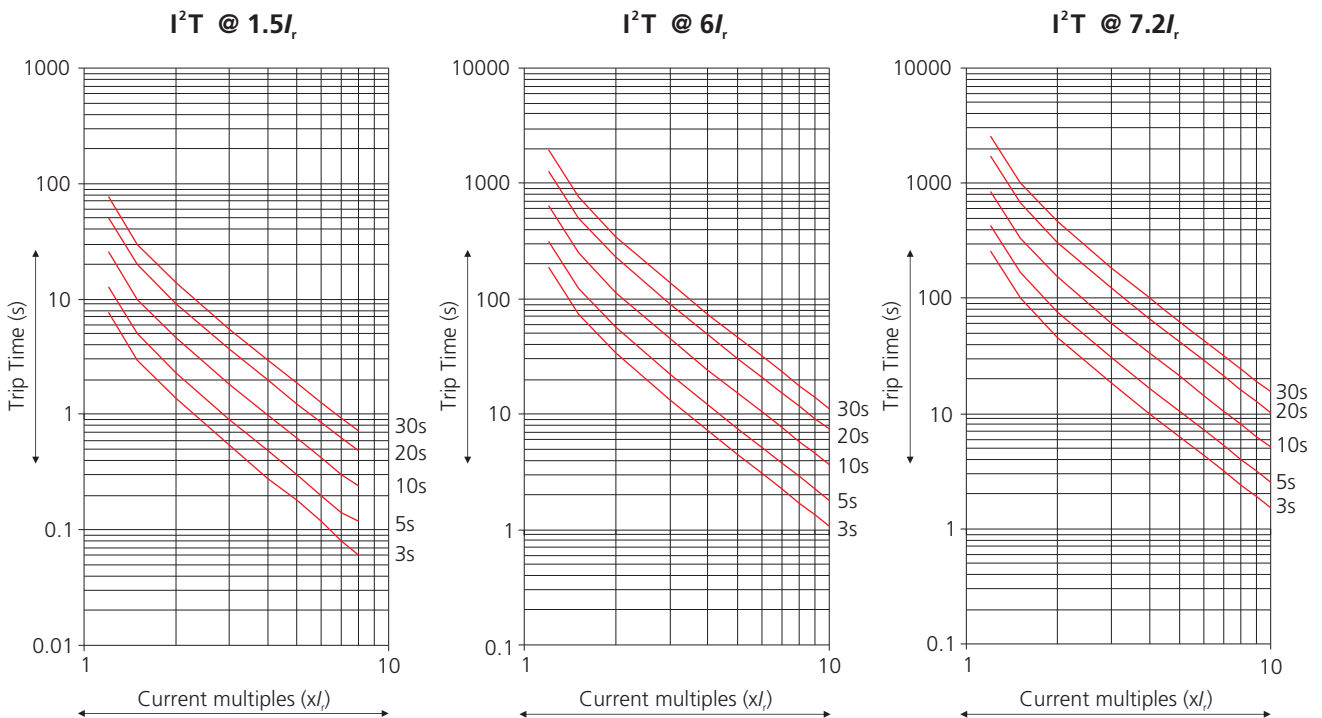

Microprocessor Release



MTX3.0 - DN2 / DN3 / DN4 (O/L curves - I^4t)

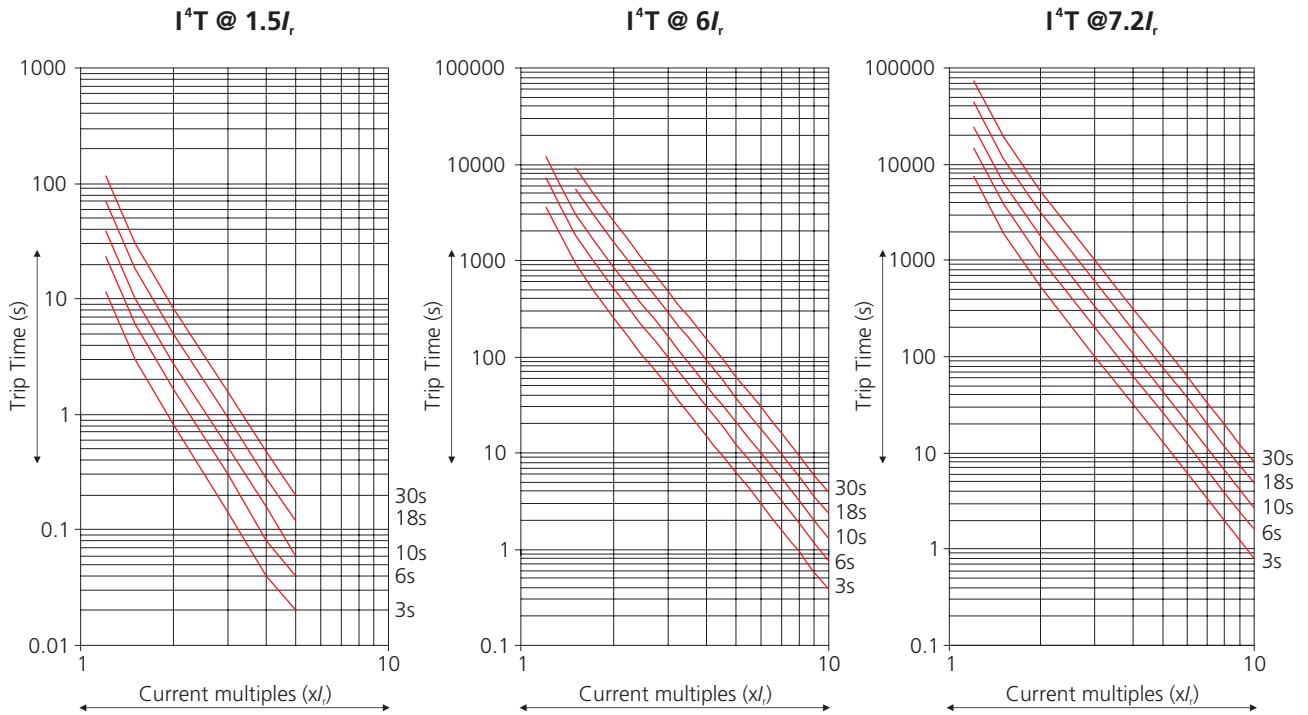

MTX3.0 - DN2 / DN3 / DN4 (O/L curves - Short Inverse)

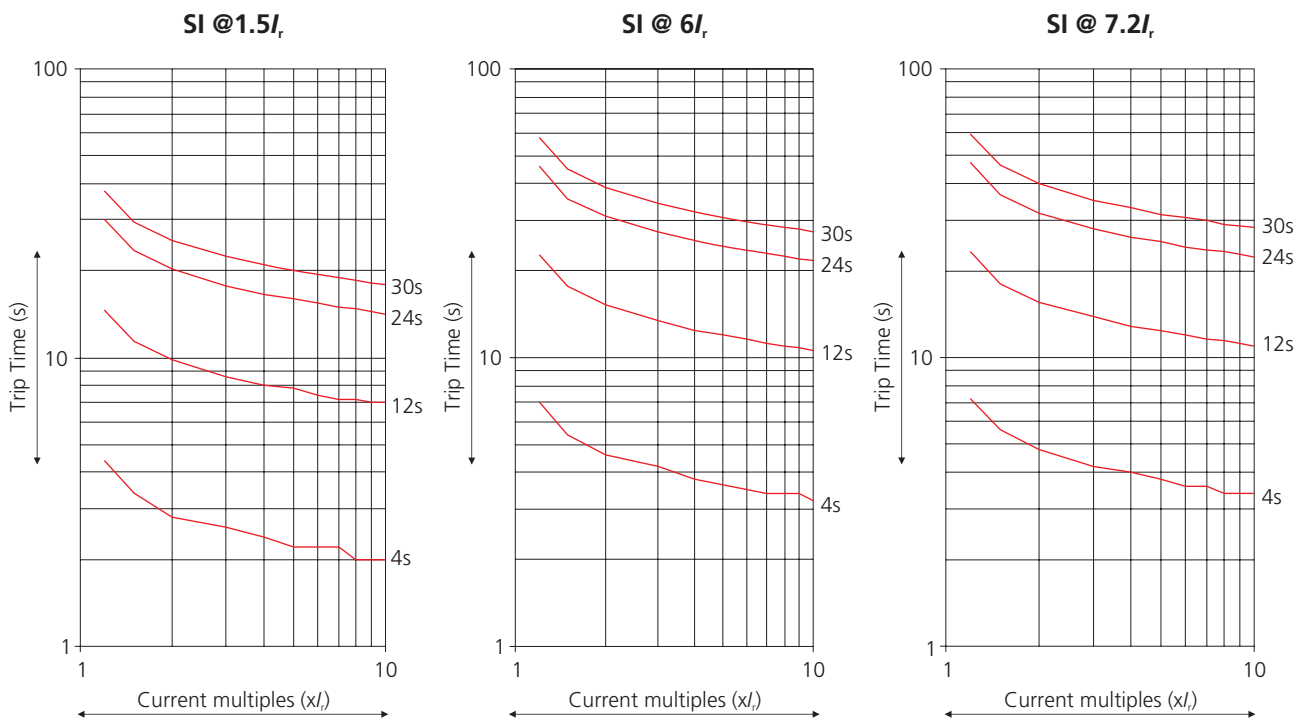

Microprocessor Release

MTX3.0 - DN2 / DN3 / DN4
(O/L curves - Long Inverse / Very Inverse)

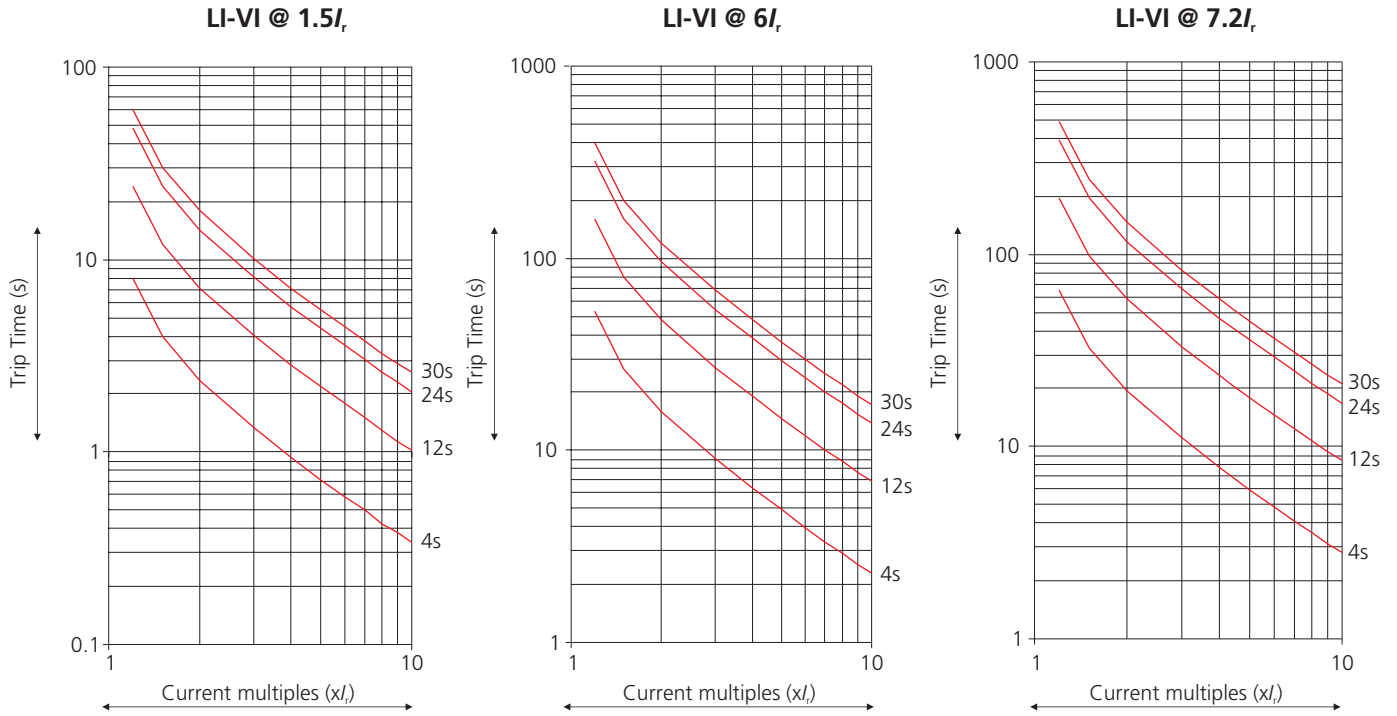

MTX1.0* / 2.0 / 3.0 (S/C, E/F & Neutral Curves)

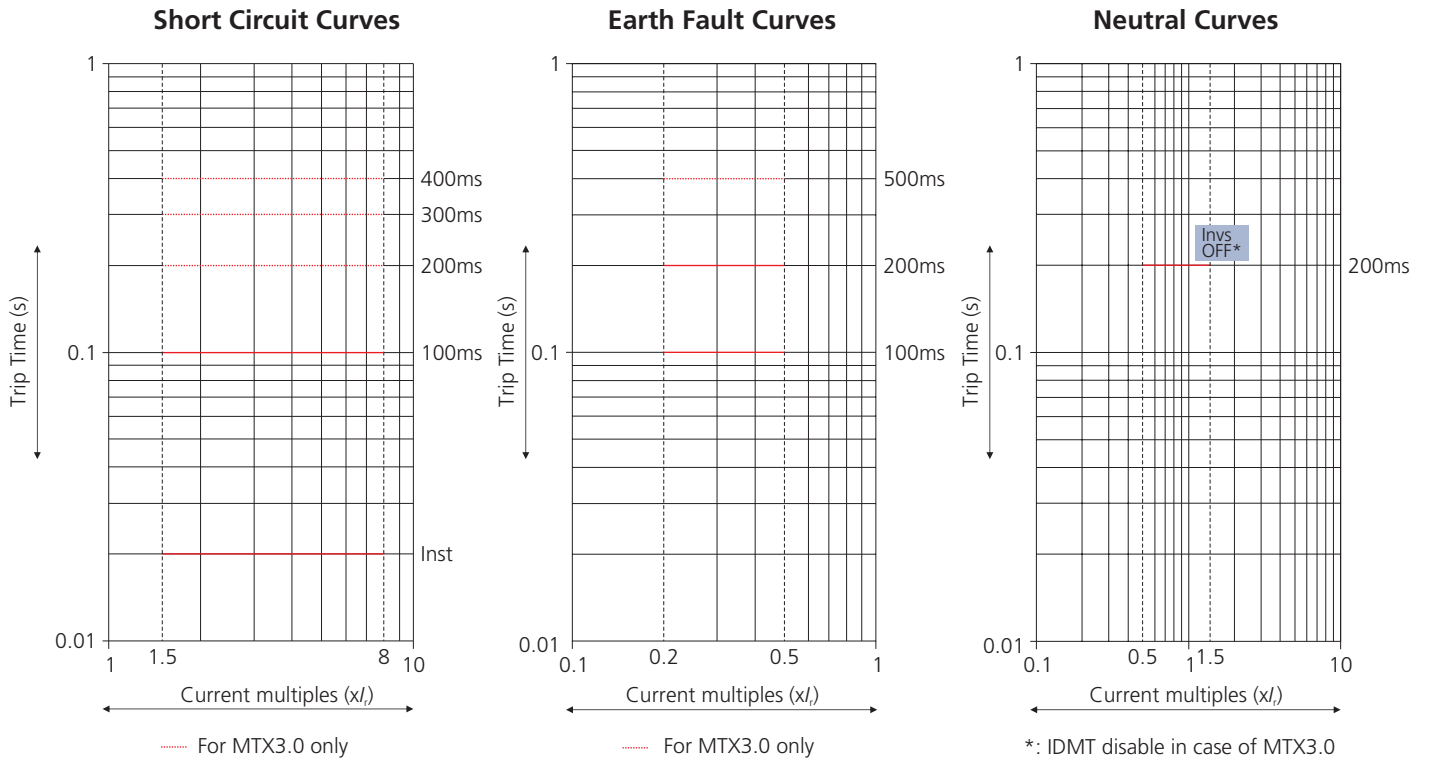

* Only Short Circuit setting available in MTX1.0
 • Under Short Circuit fault conditions, MCCBs will clear the fault in less than 10 msec



Wiring Diagrams

- Motorised Circuit Breakers Control through AuXC - 2000 60
- Earth Fault Modules 61
- MTX2.0 with Current Metering Module 62
- MTX3.0 with Communication through Modbus 63

Control of Motorised Moulded Case Circuit Breakers (Without Undervoltage Relay)

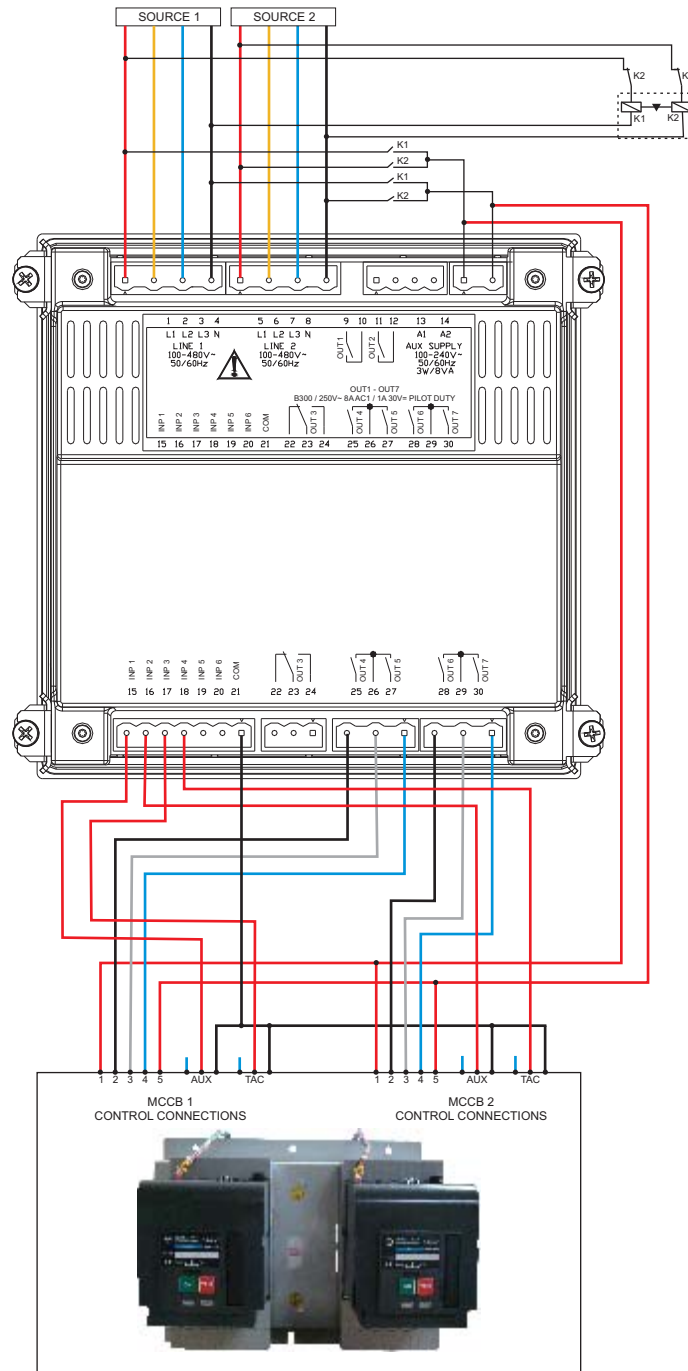

Programming	Connection Terminal	Parameter code	Setting (Description)
Others	-	P05.07	Breaker pulse or breaker continuous
Inputs	15(INP1)	P10.01.01	Line 1 breaker closed (Feedback 1)
	16(INP2)	P10.02.01	Line 2 breaker closed (Feedback 2)
	17(INP3)	P10.03.01	Line 1 circuit breaker protection (Trip 1)
	18(INP4)	P10.04.01	Line 2 circuit breaker protection (Trip 2)
Outputs	25(OUT4)	P11.04.01	Open line 1 contactor/circuit breaker
	27(OUT5)	P11.05.01	Close line 1 contactor/circuit breaker
	28(OUT6)	P11.06.01	Open line 2 contactor/circuit breaker
	30(OUT7)	P11.07.01	Close line 2 contactor/circuit breaker

Earth Fault Modules

GF1 & GF2

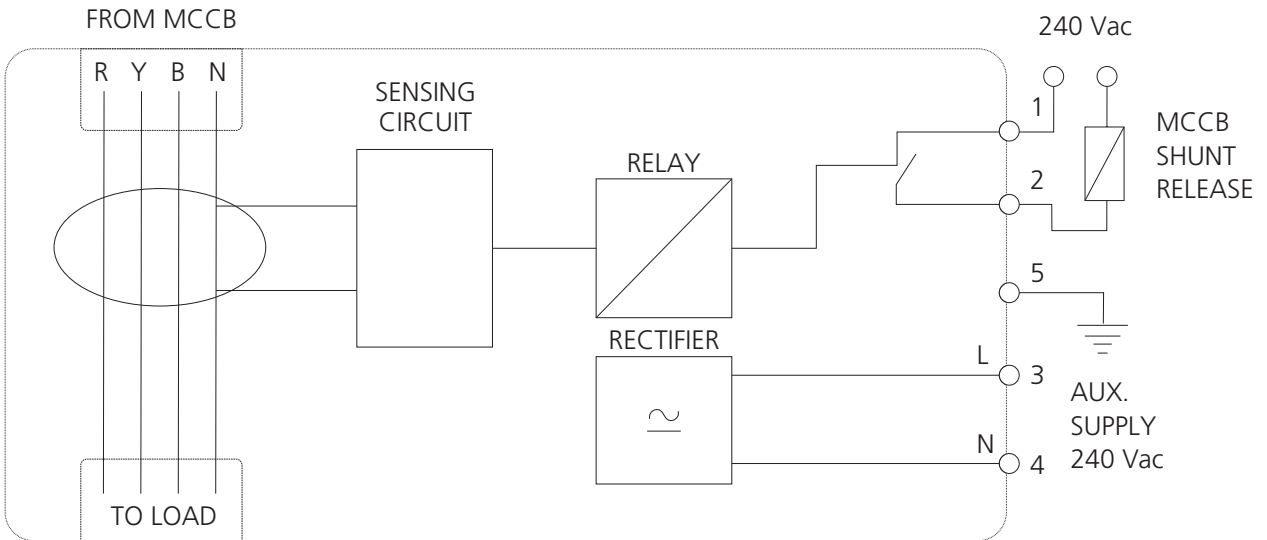

GF11

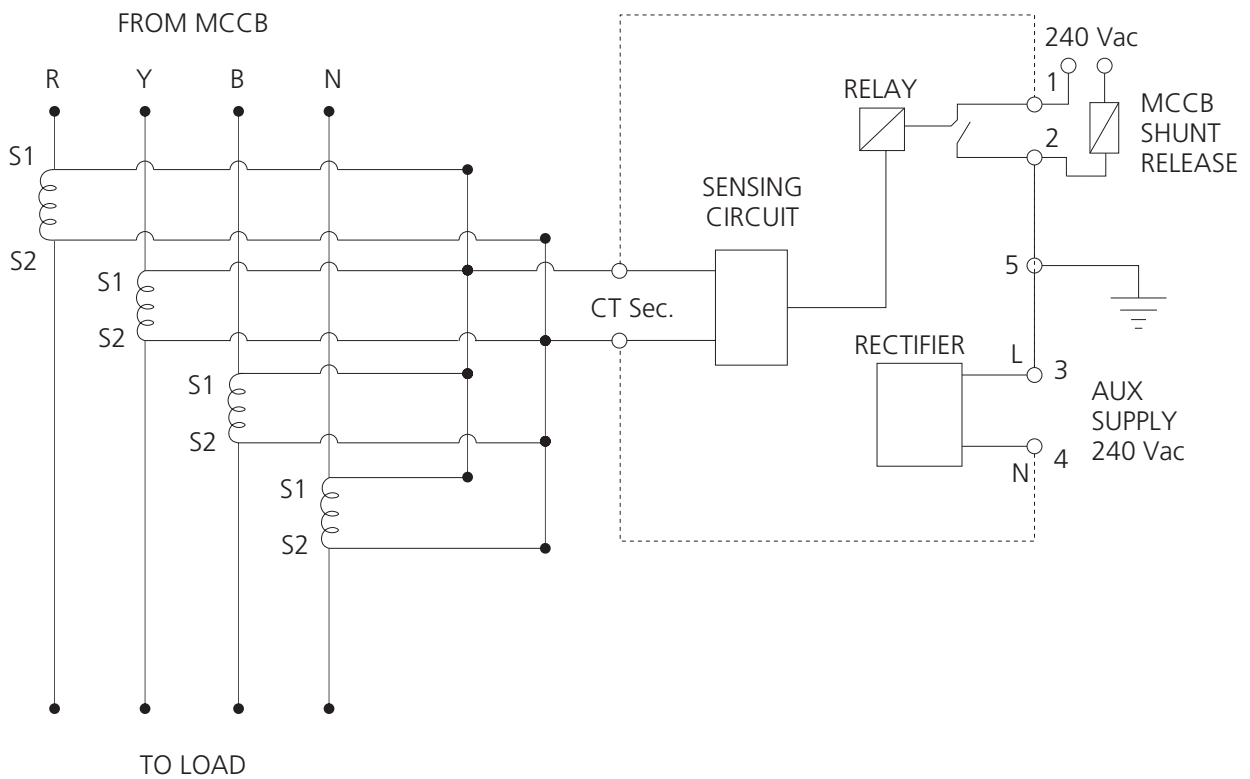

MTX2.0 with Current Metering Module

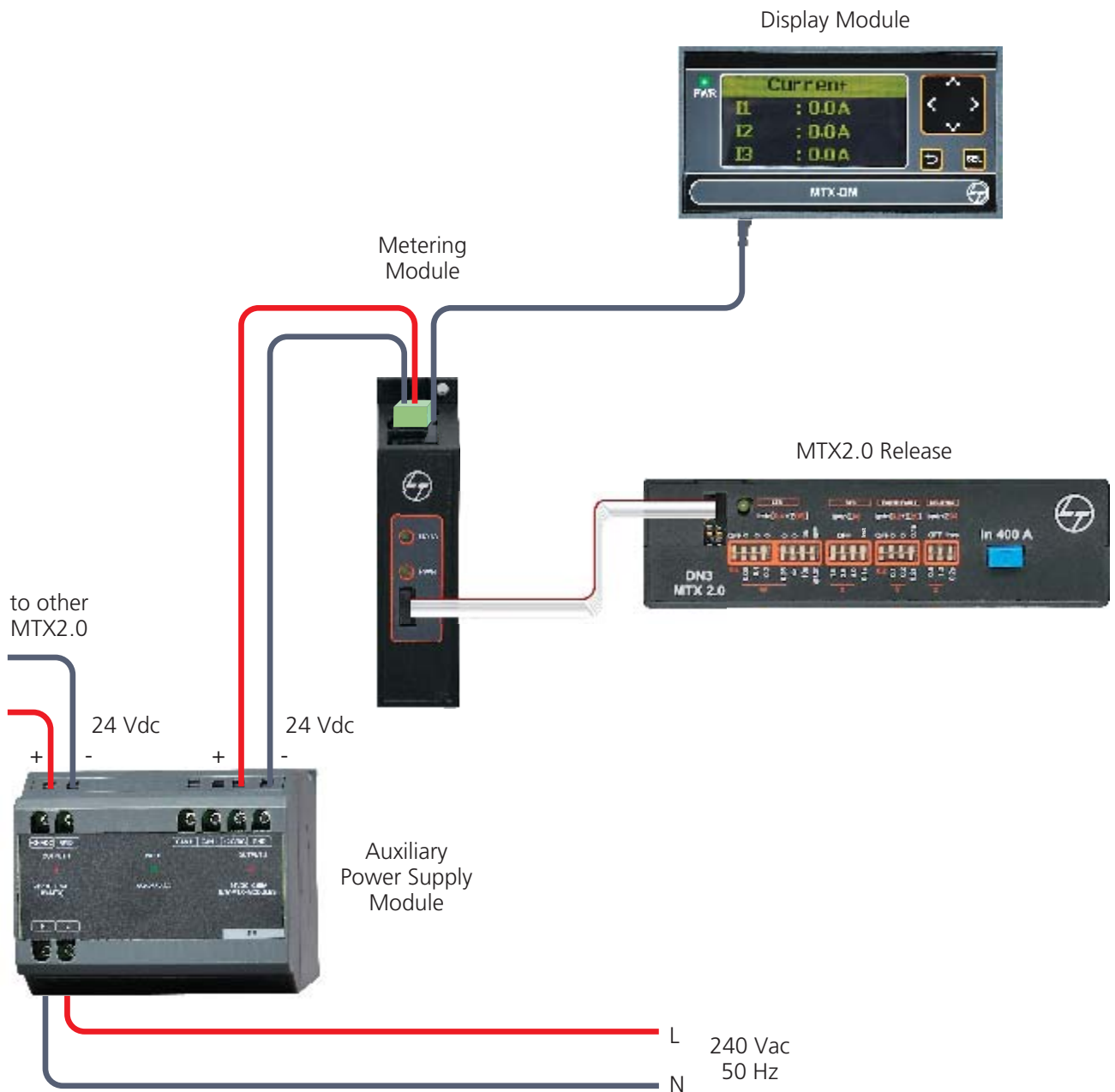

MTX3.0 with Communication through Modbus

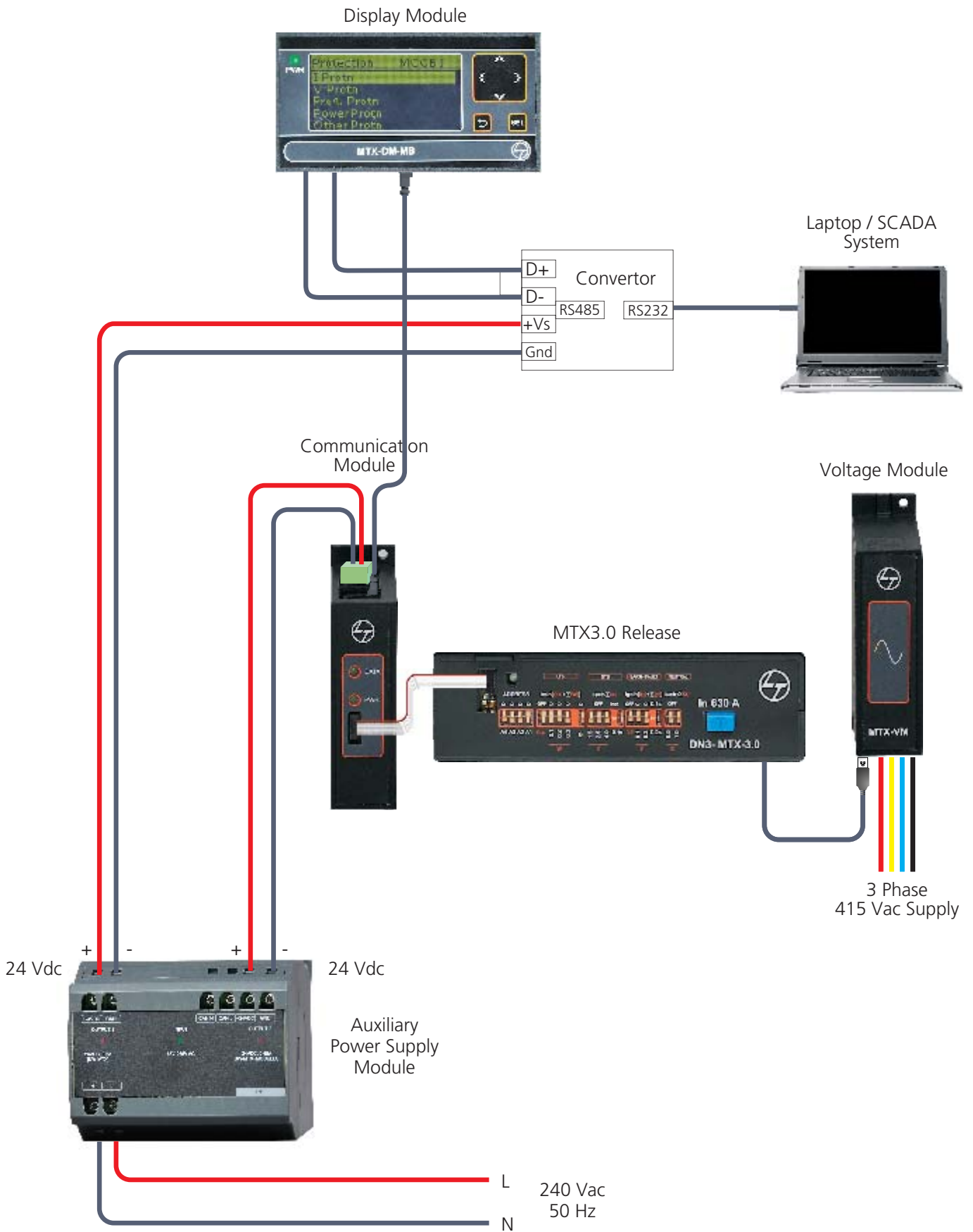





Dimensions

■ Dimensions of MCCB

66

- ▶ DN0
- ▶ DN1
- ▶ DN2
- ▶ DN3B
- ▶ DN3
- ▶ DN4

■ Dimensions of Accessory

72

- ▶ Rotary Operating Mechanism
- ▶ Stored Energy Electrically Operated Mechanism
- ▶ Panel Mounted Key Lock
- ▶ Mechanical Interlock Kit
- ▶ External Neutral CTs
- ▶ MTX Modules
- ▶ Auto Source Transfer Switch: AuXC-2000
- ▶ Earth Fault Modules
- ▶ Size I Enclosure for DN0 MCCB
- ▶ Size II Enclosure for DN1 MCCB

DN0-125 MCCB

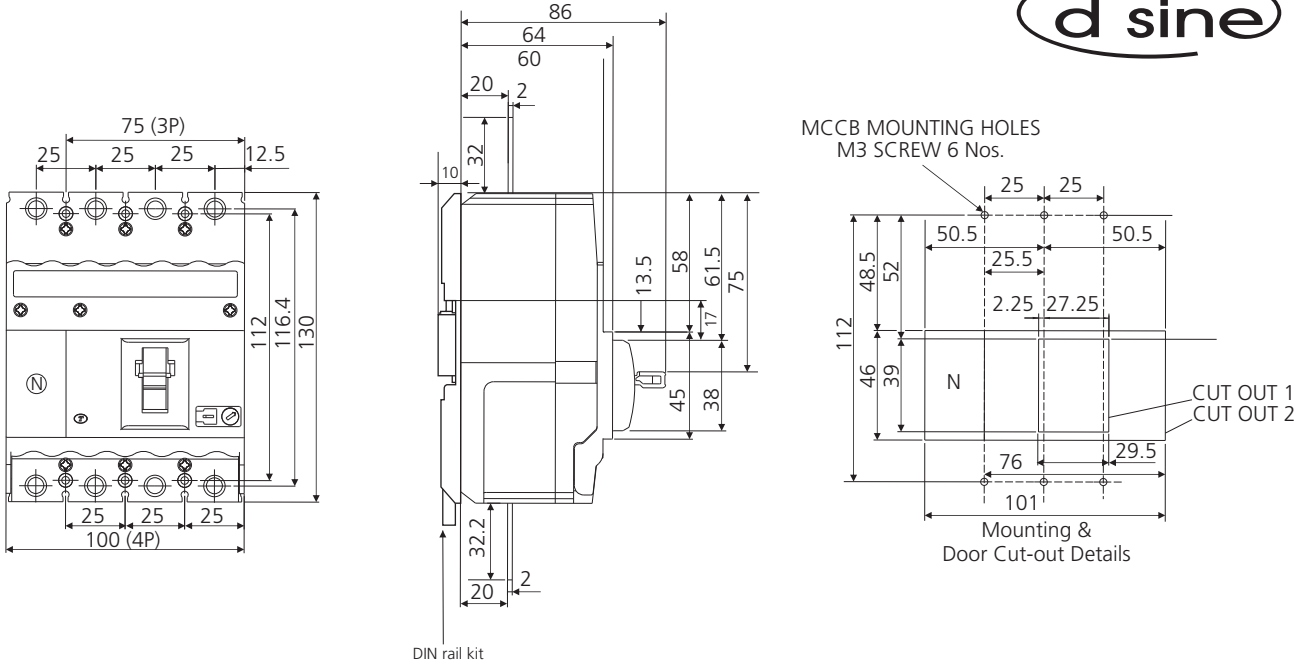

DN0-125 with Spreader Links

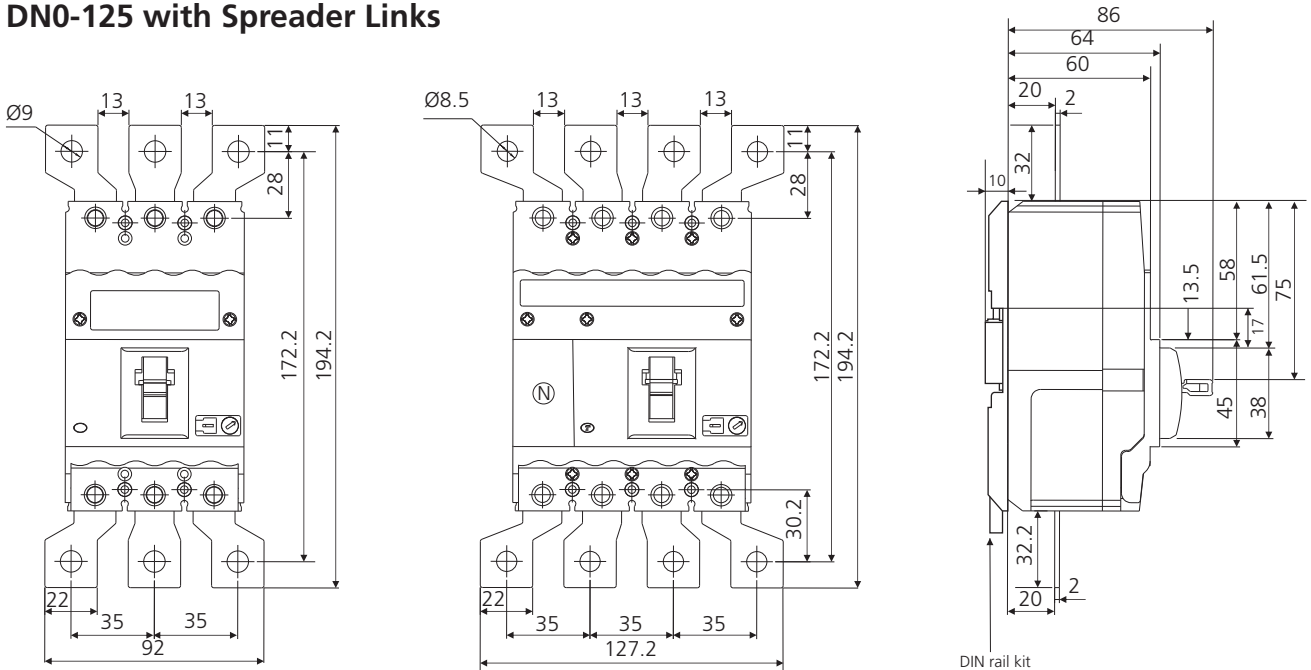

Recommended cat. nos. for DN0 spreaders

Current	3P	4P
upto 100A	CM977850000	CM979210000
125A	CM9068700LO	CM9068800LO

- Note:**
- Spreaders are available as spare
 - It is recommended to use spreader links for enhancing termination capacity
 - Frame size is same for DN0 / DN0-SD / DN0-M

All dimensions are in mm

DN1-250 MCCB

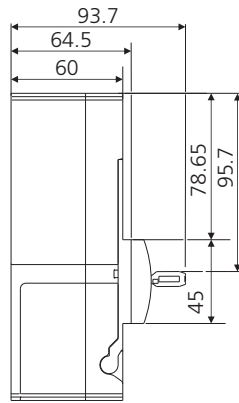
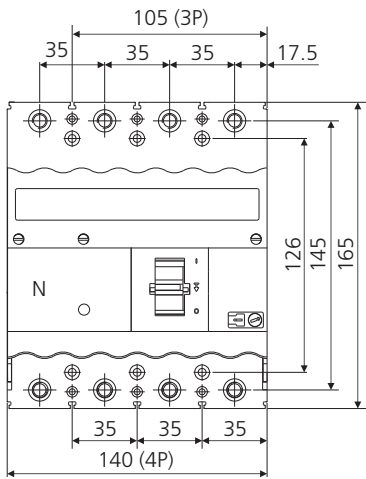

MCCB MOUNTING HOLES 6 Nos.

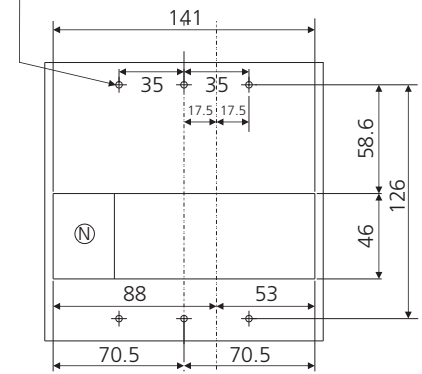

Mounting & Door Cut-out Details

DN1-250 with Spreader Links

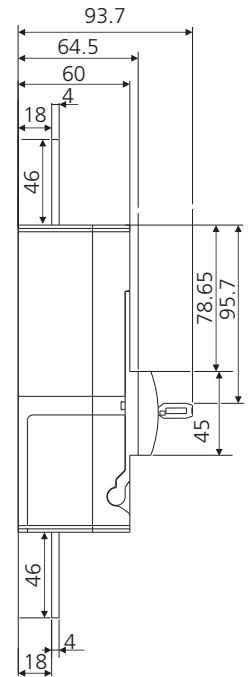
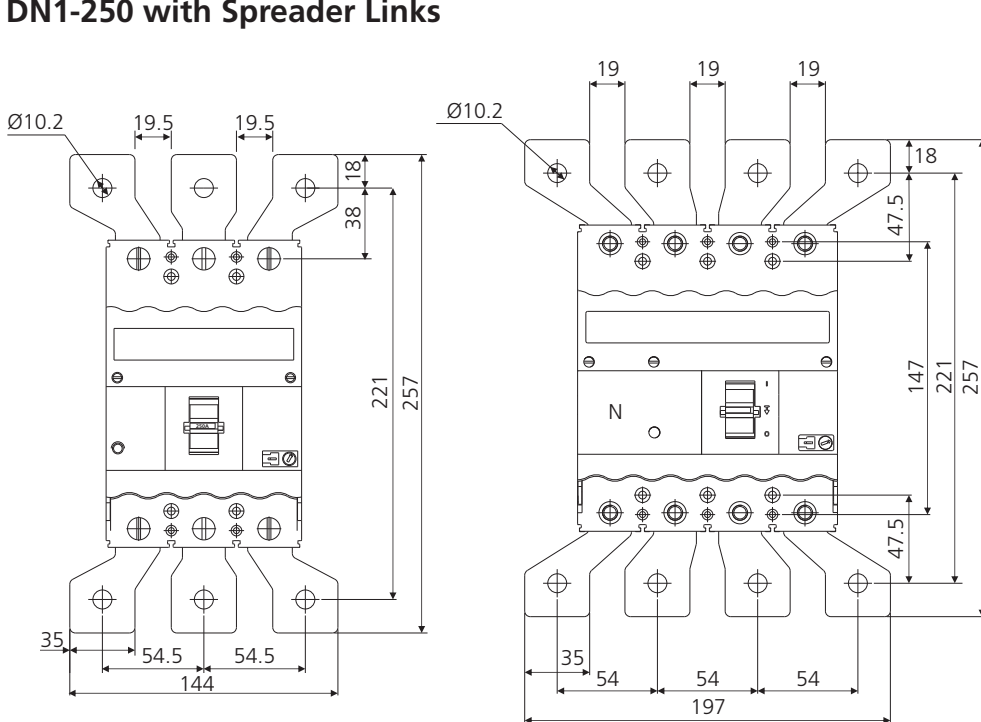

Recommended cat. nos.
for DN1 spreaders

3P	4P
ST980530000	CM920070000

- Note:**
- Spreaders are available as spare
 - It is recommended to use spreader links for enhancing termination capacity
 - Frame size is same for DN1 / DN1-M

All dimensions are in mm

DN2-250 MCCB

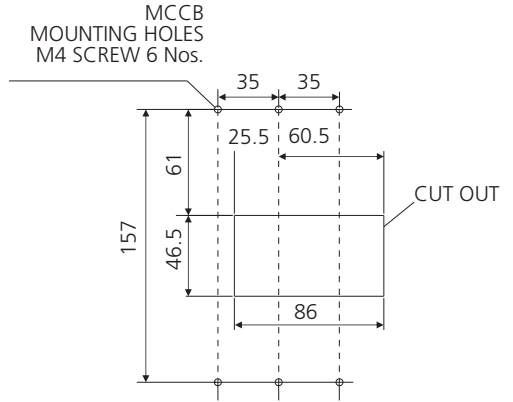
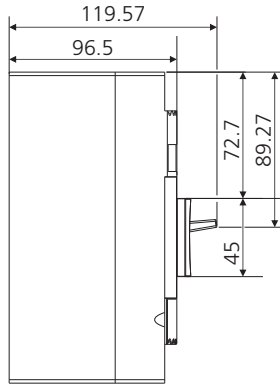
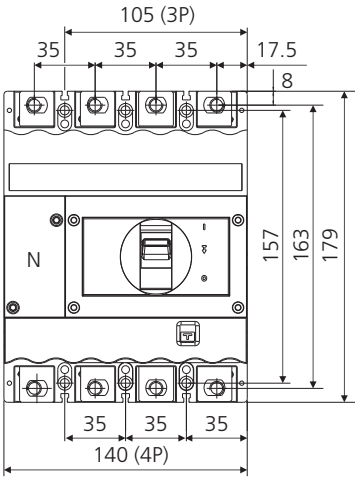

Mounting & Door Cut-out Details

DN2-250 with Spreader Links

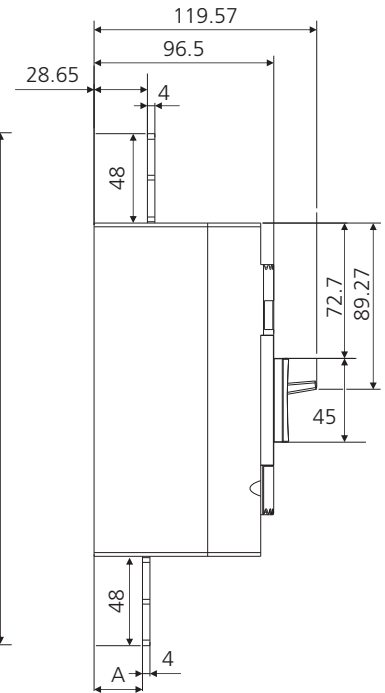
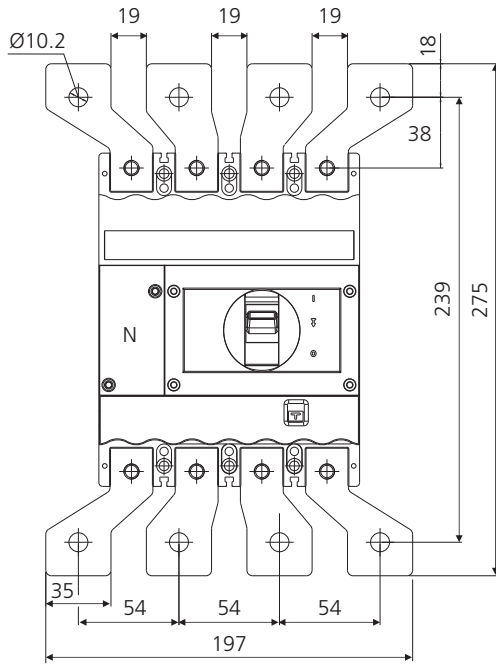
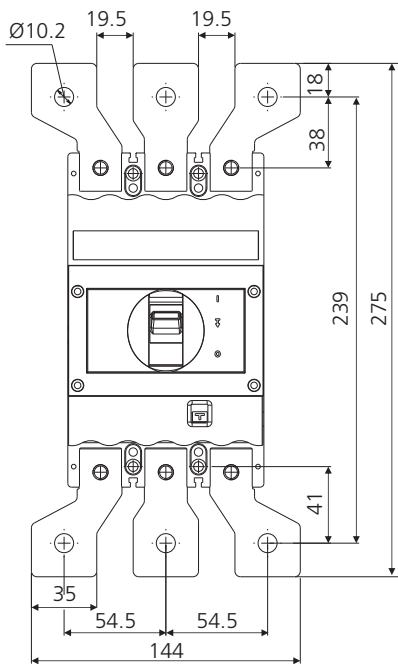

Recommended cat. nos.
for DN2 spreaders

3P	4P
ST980530000	CM920070000

Rating	Dimension (A)
125-250A TM	26
63-100A TM	25.5
32-50A TM	26.25
MTX breakers	28

- Note:**
- Spreaders are available as spare
 - It is recommended to use spreader links for enhancing termination capacity
 - Frame size is same for DN2 / DN2-SD / DN2-M

All dimensions are in mm

DN3B-400 MCCB

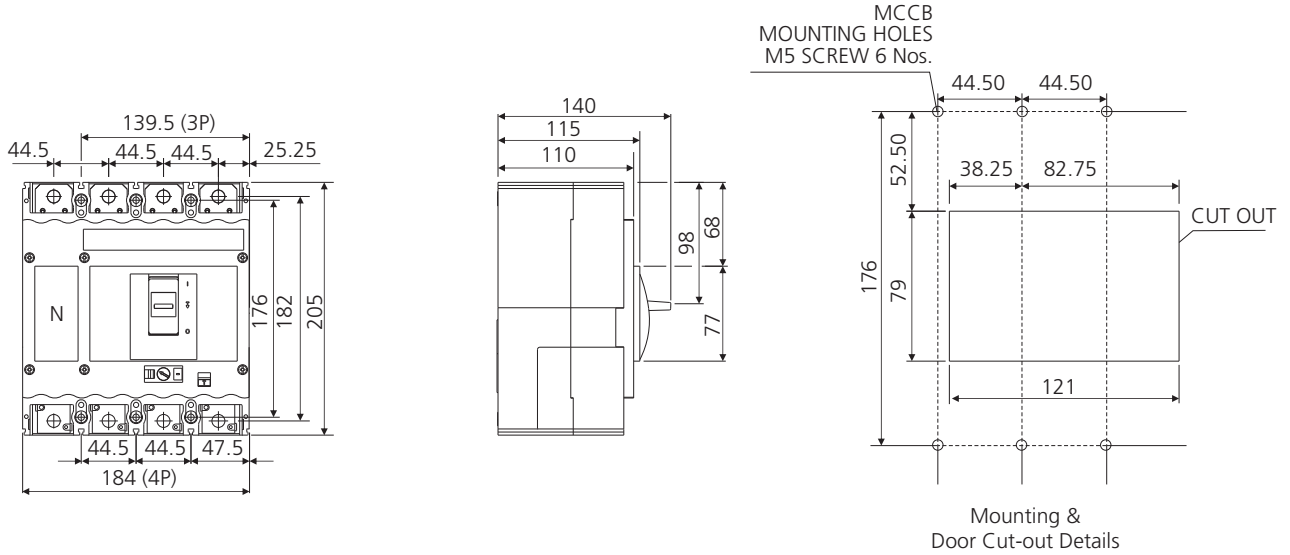

DN3B-400 with Spreader Links

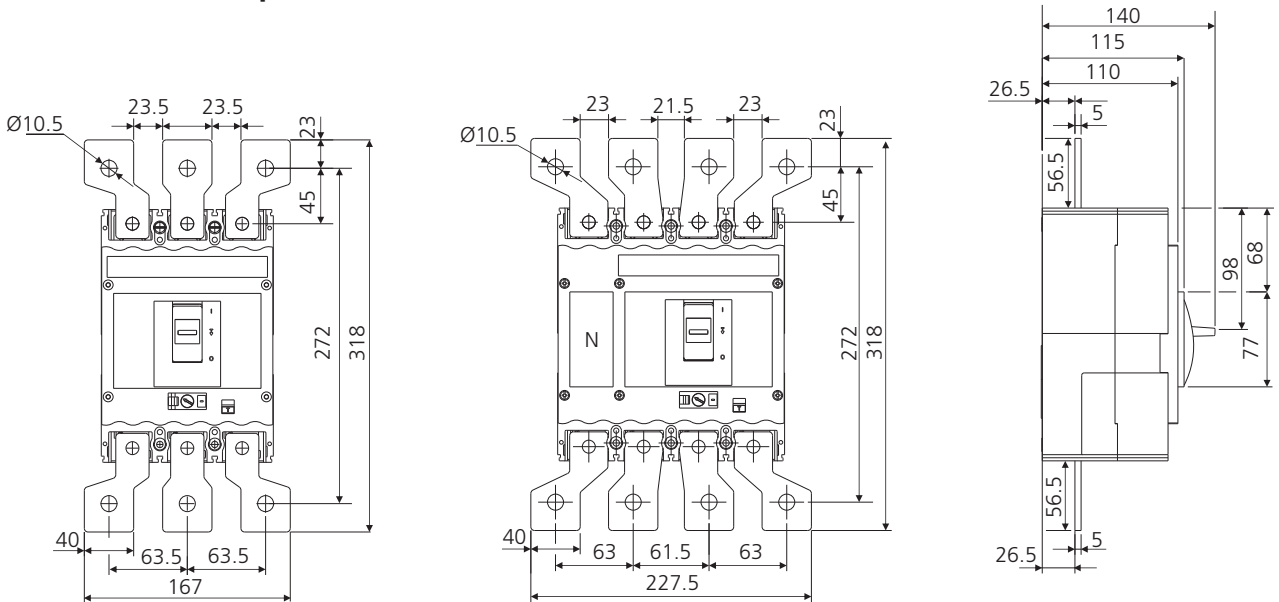

**Recommended cat nos.
for DN3B spreaders**

3P	4P
ST980650000	ST980660000

- Note:**
- Spreaders are available as spare
 - It is recommended to use spreader links for enhancing termination capacity
 - Frame size is same for DN3B / DN3B-SD

All dimensions are in mm

DN3-400/630 MCCB

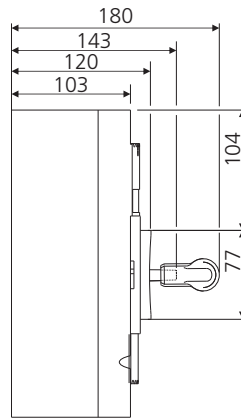
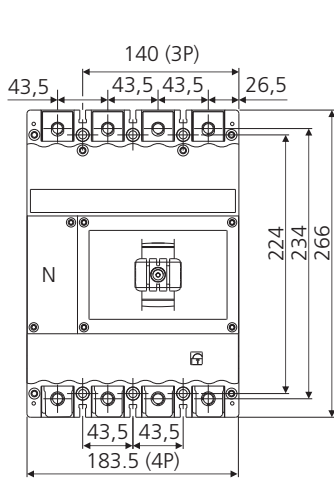

MCCB MOUNTING HOLES
M5 SCREW 6 Nos.

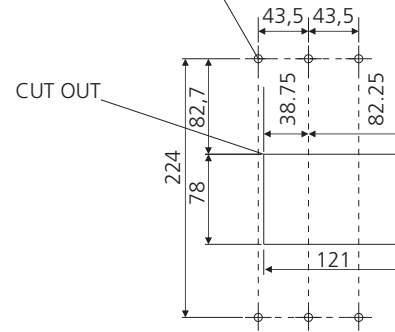

Mounting & Door Cut-out Details

DN3-400/630 with Spreader Links

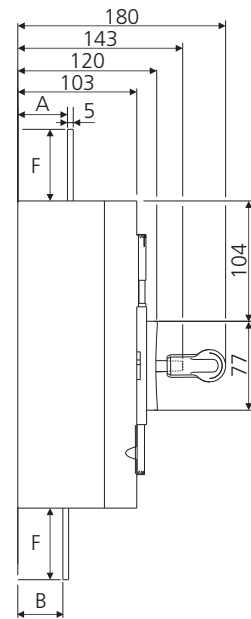
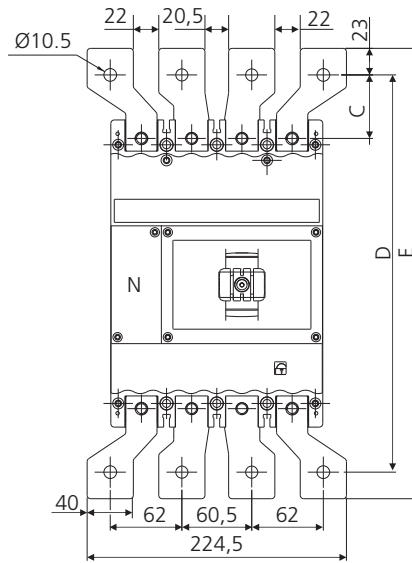
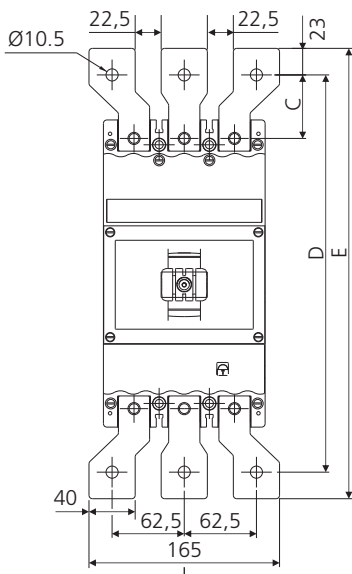

Recommended cat nos.
for DN3 spreaders

Rating	3P	4P
400A	ST980650000	ST980660000
630A	ST980540000	CM920040000

Type	DN3-400	DN3-630
A	39	43
B	37*	39#
C	45	55
D	324	344
E	370	390
F	52	62

* 38 for MTX
38 for 500A TM

Note:

- Spreaders are available as spare
- It is recommended to use spreader links for enhancing termination capacity
- Frame size is same for DN3 / DN3-SD / DN3-M

All dimensions are in mm

DN4-800/1000/1250 MCCB

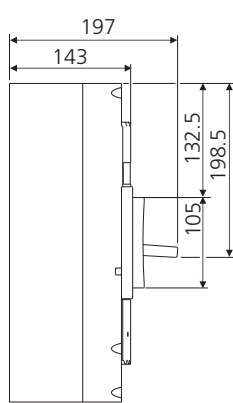
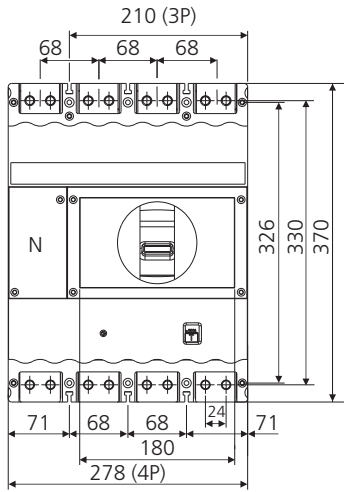

MCCB MOUNTING HOLES M5 SCREW 6 Nos.

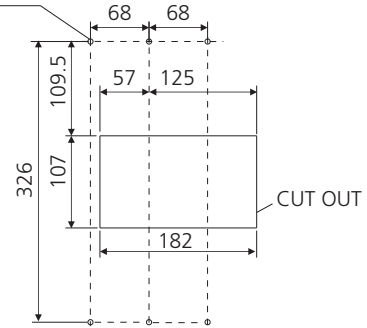

Mounting & Door Cut-out Details

DN4-800/1000/1250 with Spreader Links

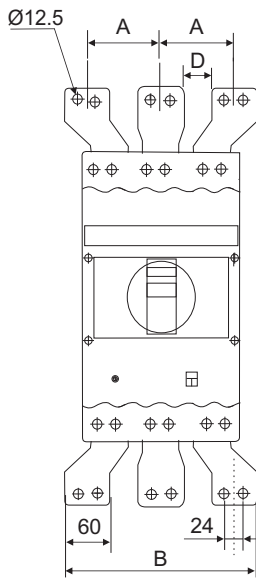

3P Frame

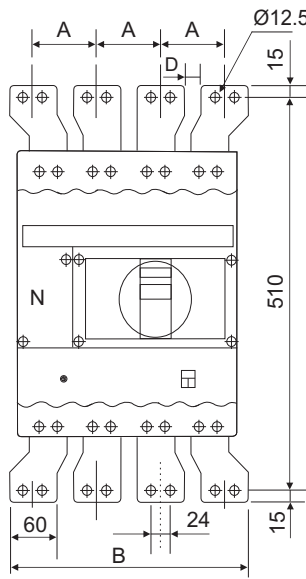

4P Frame

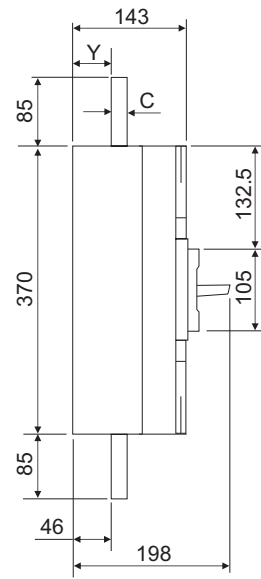

3/4P Frame

Type	A	B	C	D
800A	98	256	6	38
1000A	98	256	12	38
1250A	86	232	20	26

Type	A	B	C	D
800A	88	324	6	28
1000A	88	324	12	28
1250A	80	300	20	20

Type	Y
N version	46
S version	42

Recommended cat nos. for DN4 spreaders

Rating	3P	4P
800A	CM911610OUO	ST903620OOO
1000A	CM911610OVO	CM900640OVO
1250A	CM911610OAO	ST980580OOO

- Note:**
- Spreaders are available as spare
 - It is recommended to use spreader links for enhancing termination capacity
 - Frame size is same for DN4 / DN4-SD

All dimensions are in mm

Rotary Operating Mechanism (ROM)

Direct ROM Door Cut-out Detail

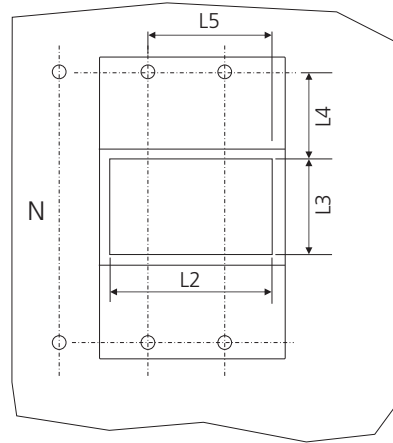
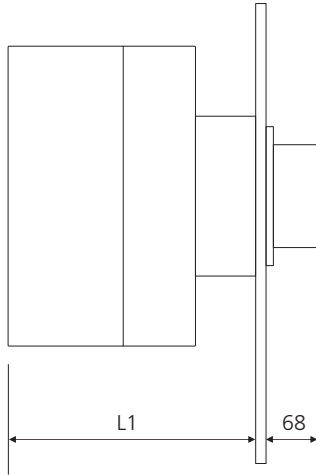

Mounting & Door Cut-out Details

- L1 = Mounting Depth
- L2/L3 = Panel Cut-out
- L4/L5 = Breaker Mounting Refer

Type	L1	L2	L3	L4	L5
DN0	96.5	58	52	43.5	37
DN1	96.5	73	52	56.5	54
DN2	122	96	63	53	66
DN3	146	121	87	78	82
DN3B	146	121	87	49	82.5

Extended ROM Door Cut-out Detail

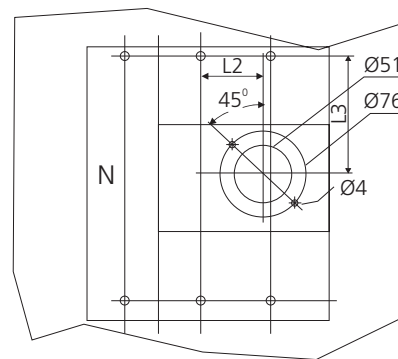
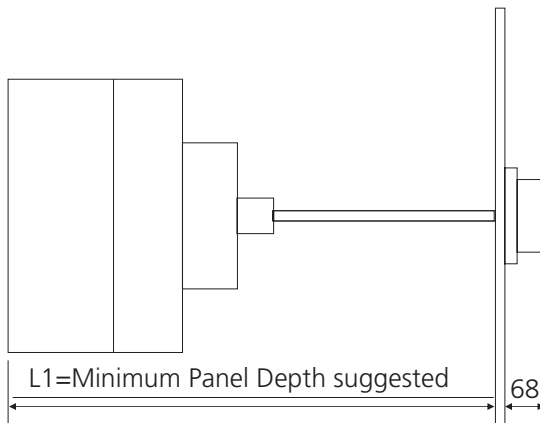

Mounting & Door Cut-out Details



L = Length of Shaft Required for Panel Depth L1
 Total Length of Shaft = 275mm

Type	L1	L	L2	L3
DN0	169	L1 - 119	7.5	69.5
DN1	169	L1 - 119	24.5	81.7
DN2	202	L1 - 152	27	84
DN3	233	L1 - 183	39	122
DN3B	233	L1 - 183	39	92
DN4	302	L1 - 252	69	170

All dimensions are in mm

MCCB with Stored Energy Electrically Operated Mechanism (SE-EOM)



DN2

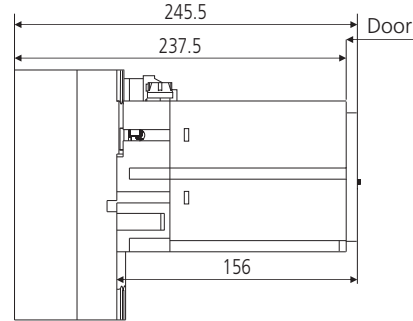
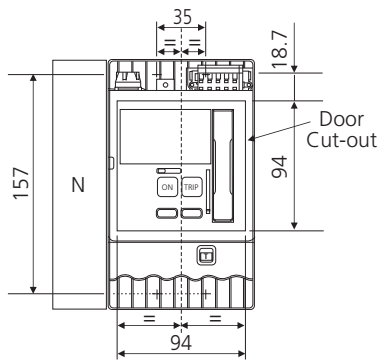

DN3

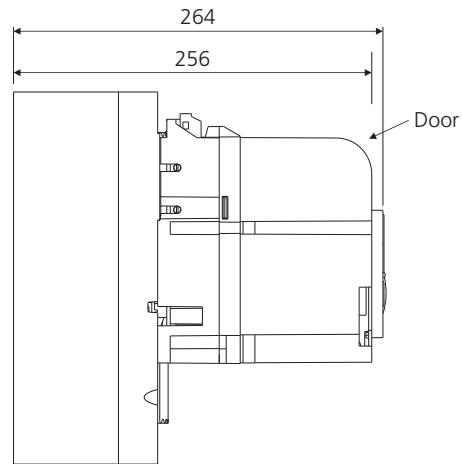
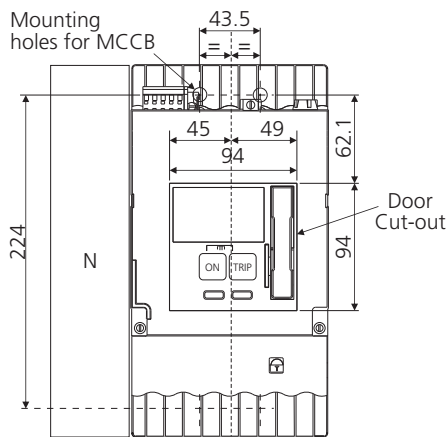

Panel Mounted Key Lock Type 1 / 2 / 3 / 12 / 23

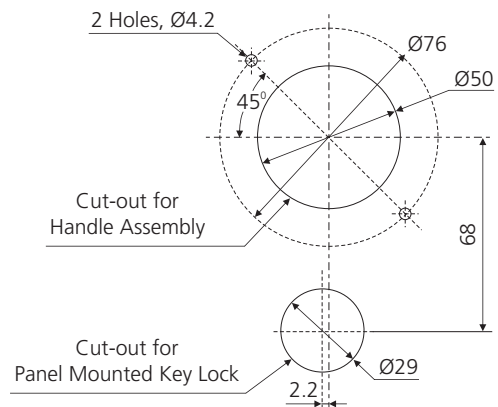
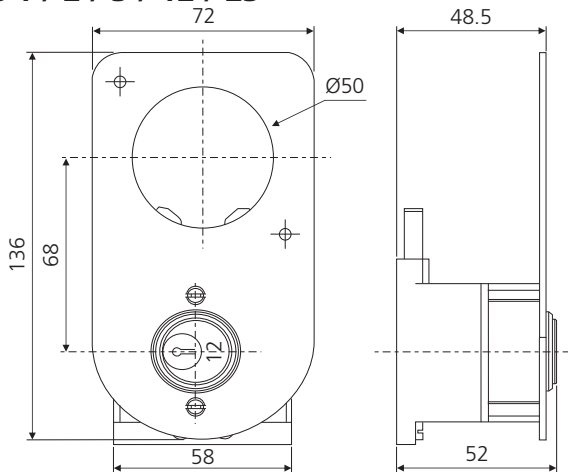

Mounting & Door Cut-out Details

Note: Panel Mounted key lock can be used only with extended ROM

All dimensions are in mm

Mechanical Interlocking Kit



DN2

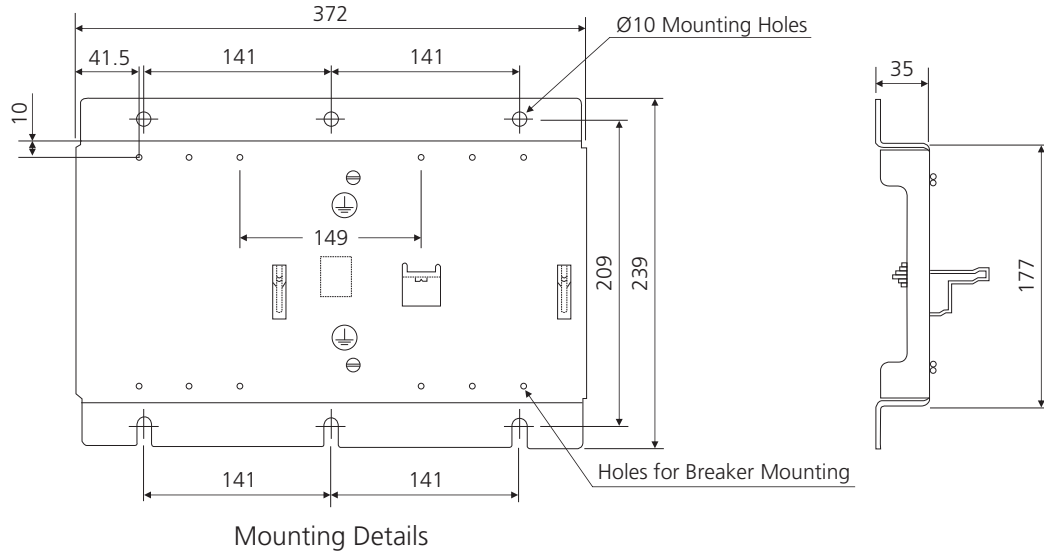

DN3

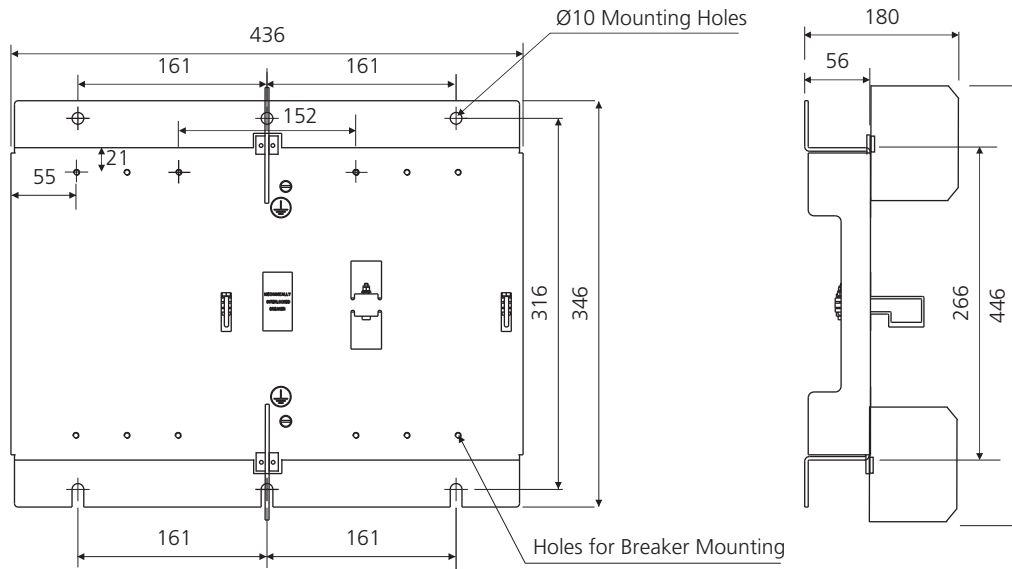

All dimensions are in mm

External Neutral CTs

DN2/DN3

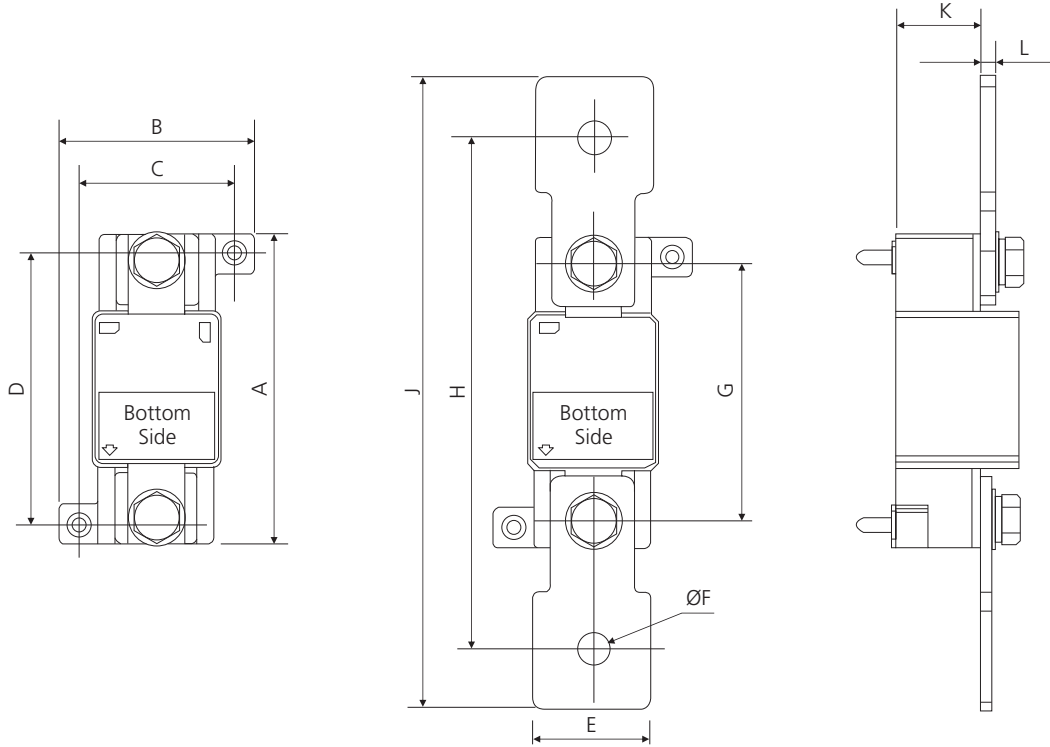

Frame	A	B	C	D	E	F
DN2 250A	93	59	47	81	35	10.2
DN3 400A	93.5	58	46	81.5	40	13
DN3 630A	93.5	58	46	81.5	40	10.5

Frame	G	H	J	K	L	M
DN2 250A	77	153	189	26	4	55
DN3 400A	63.5	153.5	199.5	39	5	60
DN3 630A	63.5	173.5	219.5	39	5	60

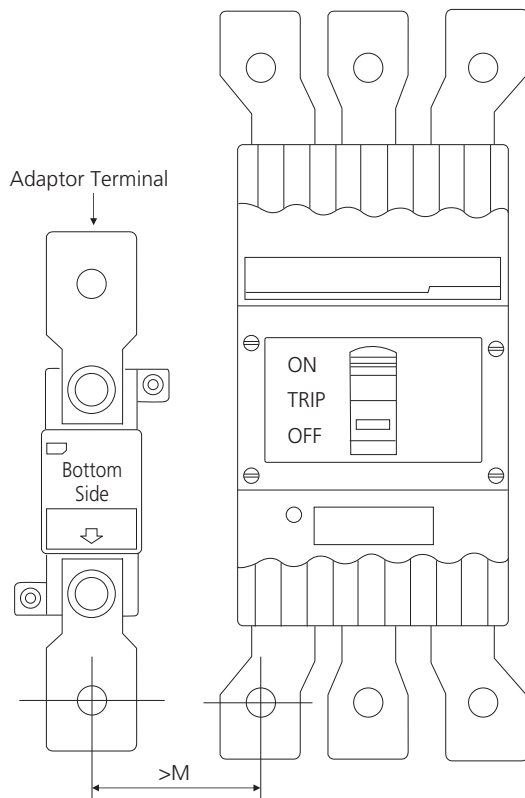

Note:

- Adaptor Terminals shown are not available with product
- Kindly refer accessories data for ordering separately
- Circuit Breaker shown for reference only

All dimensions are in mm

External Neutral CTs

DN4

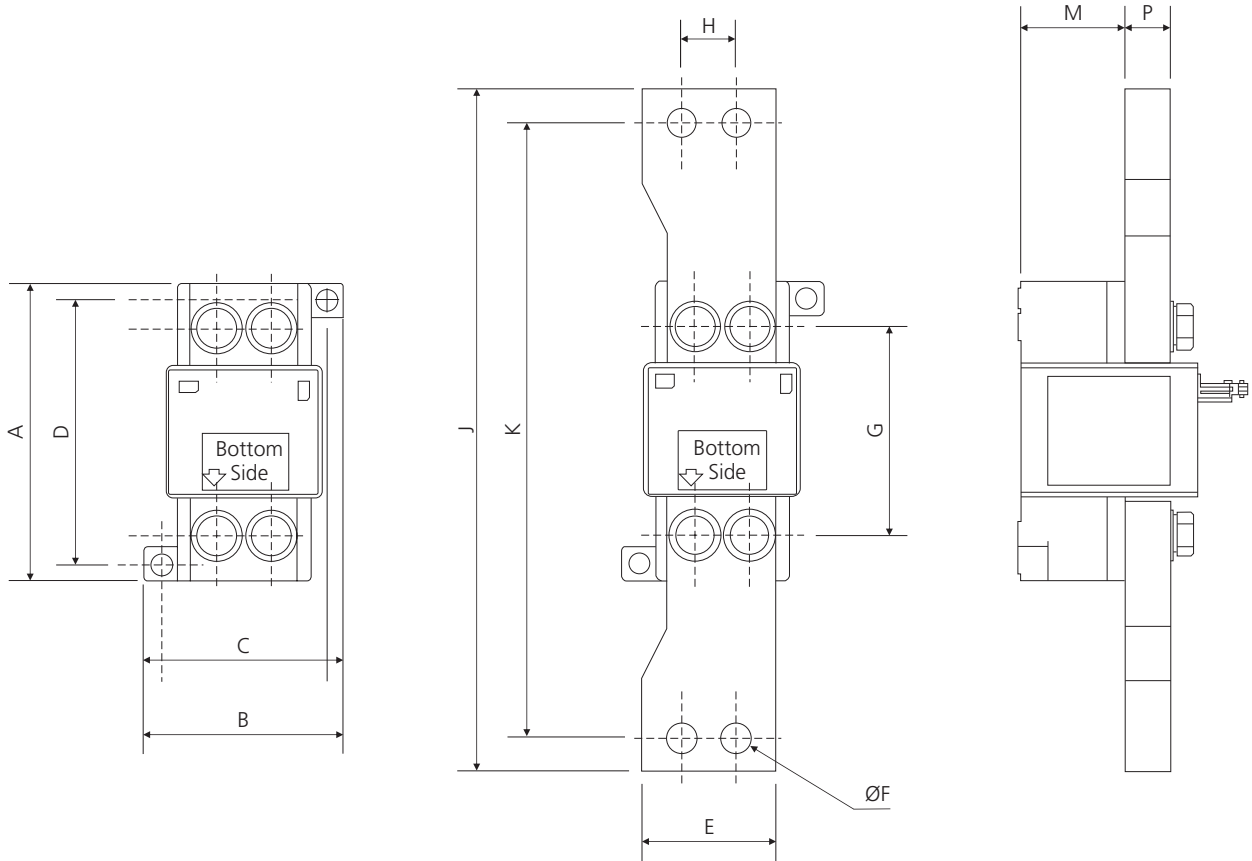

DN4	A	B	C	D	E	F	G
800A	132	88.5	73.5	117	60	12.5	92
1000A	132	88.5	73.5	117	60	12.5	92
1250A	132	88.5	73.5	117	60	12.5	92

DN4	H	J	K	L	M	P
800A	24	302	272	80	47	6
1000A	24	302	272	80	47	12
1250A	24	302	272	80	47	20

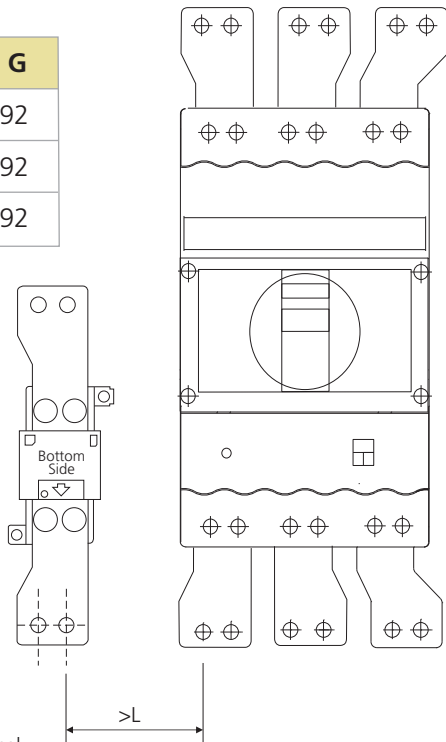

Note:

- Adaptor Terminals shown are not available with product
- Kindly refer accessories data for ordering separately
- Circuit Breaker shown for reference only

Special Note:

- Adaptor Terminals for DN4 range of product are not symmetrical.
- Kindly ensure proper orientation in assembly as shown in figure.

All dimensions are in mm

MTX Modules

Display Module

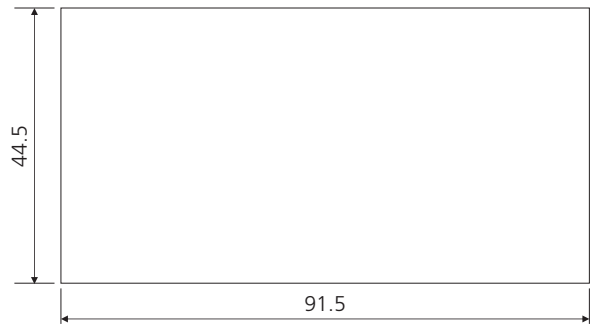
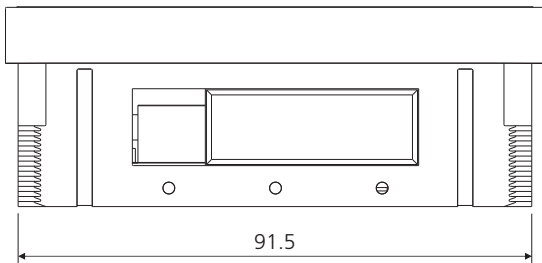
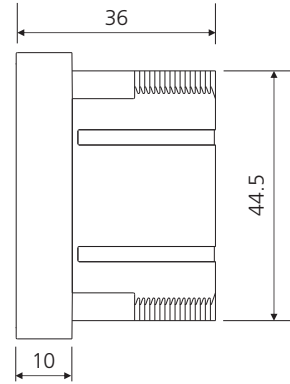
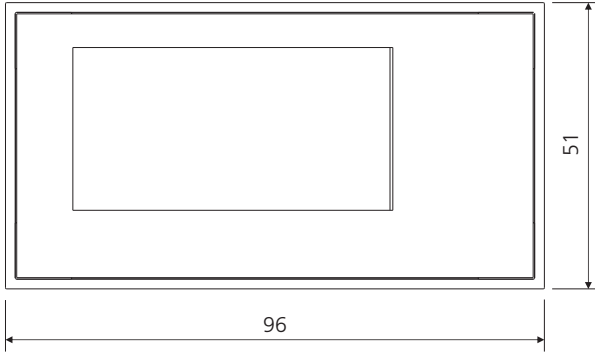

Door Cut-out Details

Voltage/Communication/Metering Module

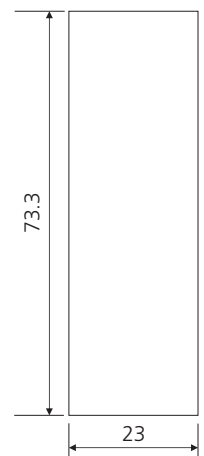
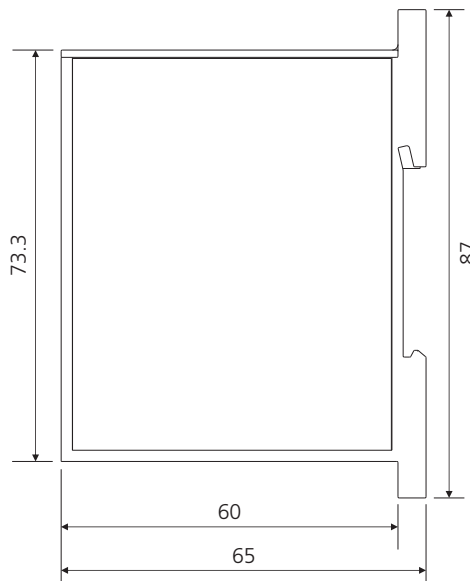
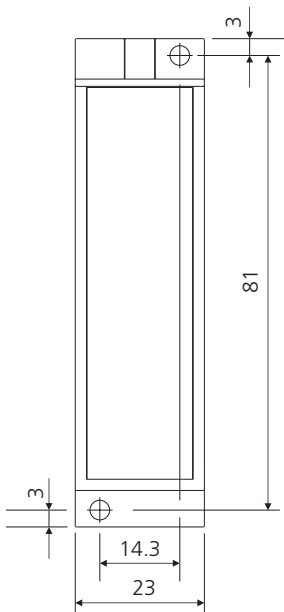

Door Cut-out Details

All dimensions are in mm

**Auto Source Transfer Switch:
AuXC-1000 and AuXC-2000**

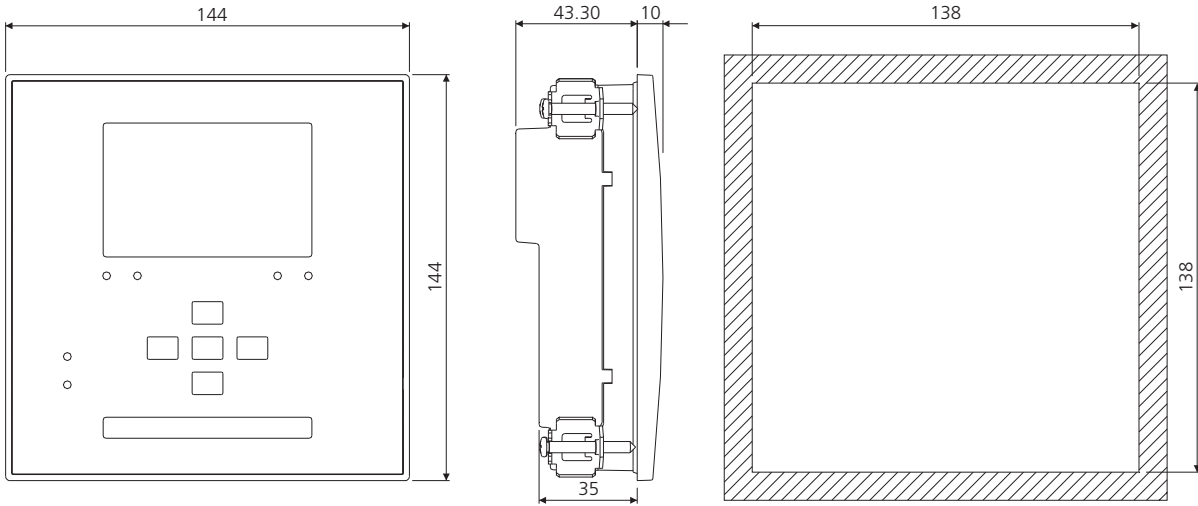

Earth Fault Modules - GF1, GF2, GF11

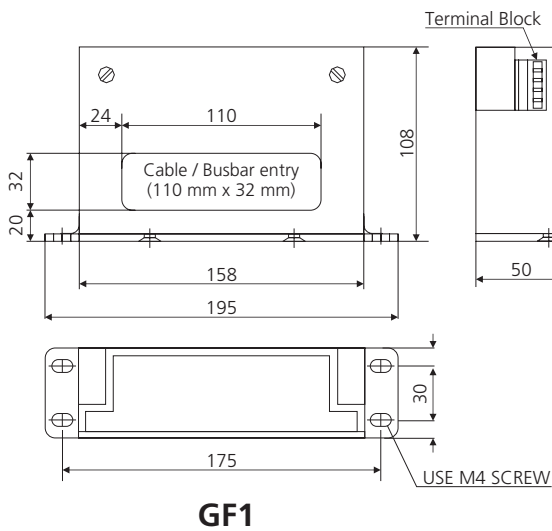

GF1

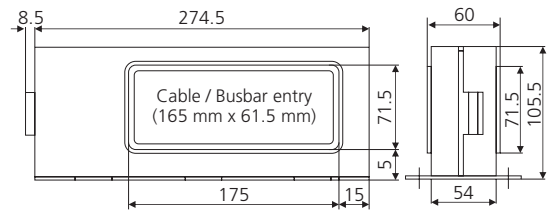

USE M6 SCREW

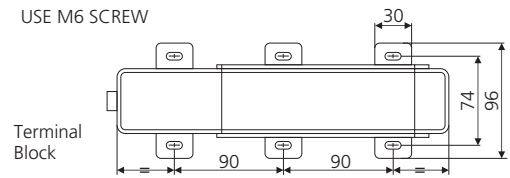

GF2

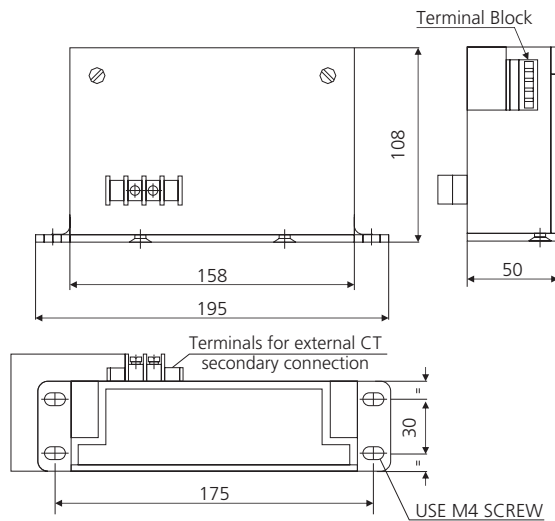

GF11

All dimensions are in mm

Size I Enclosure for DN0 MCCB

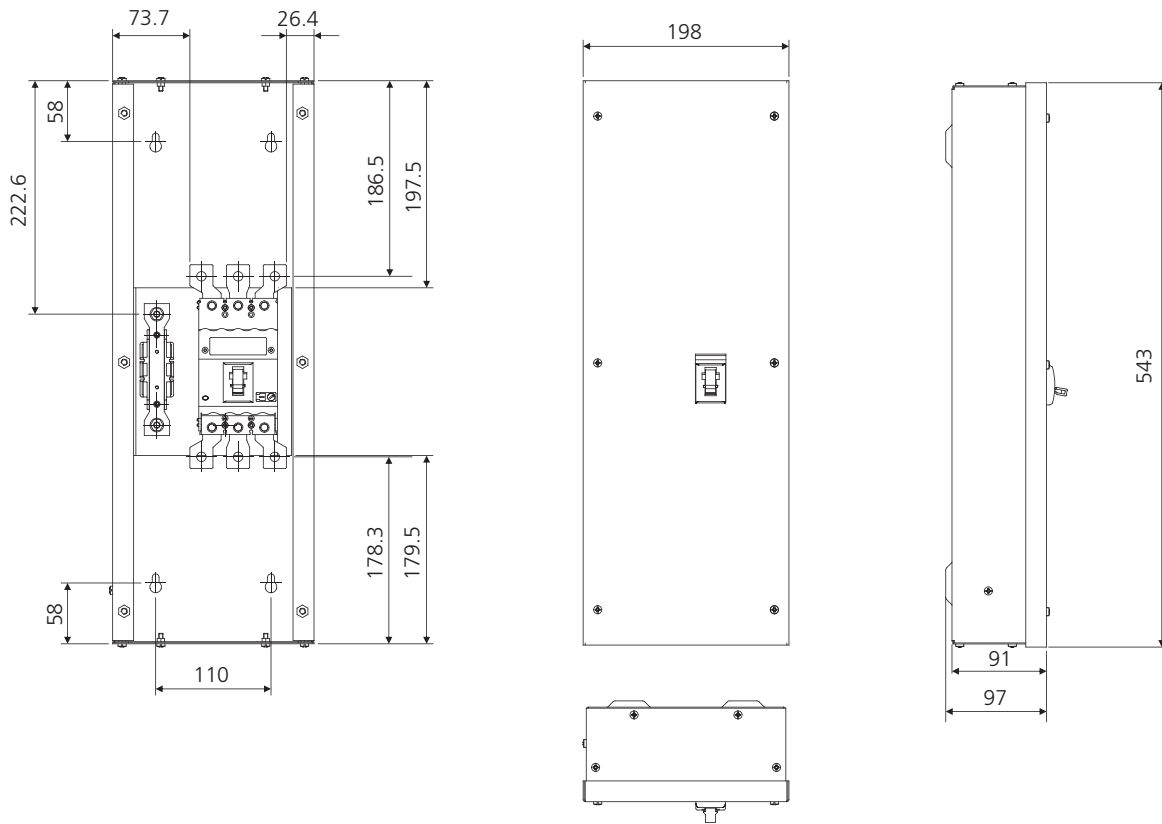

Size II Enclosure for DN1 MCCB

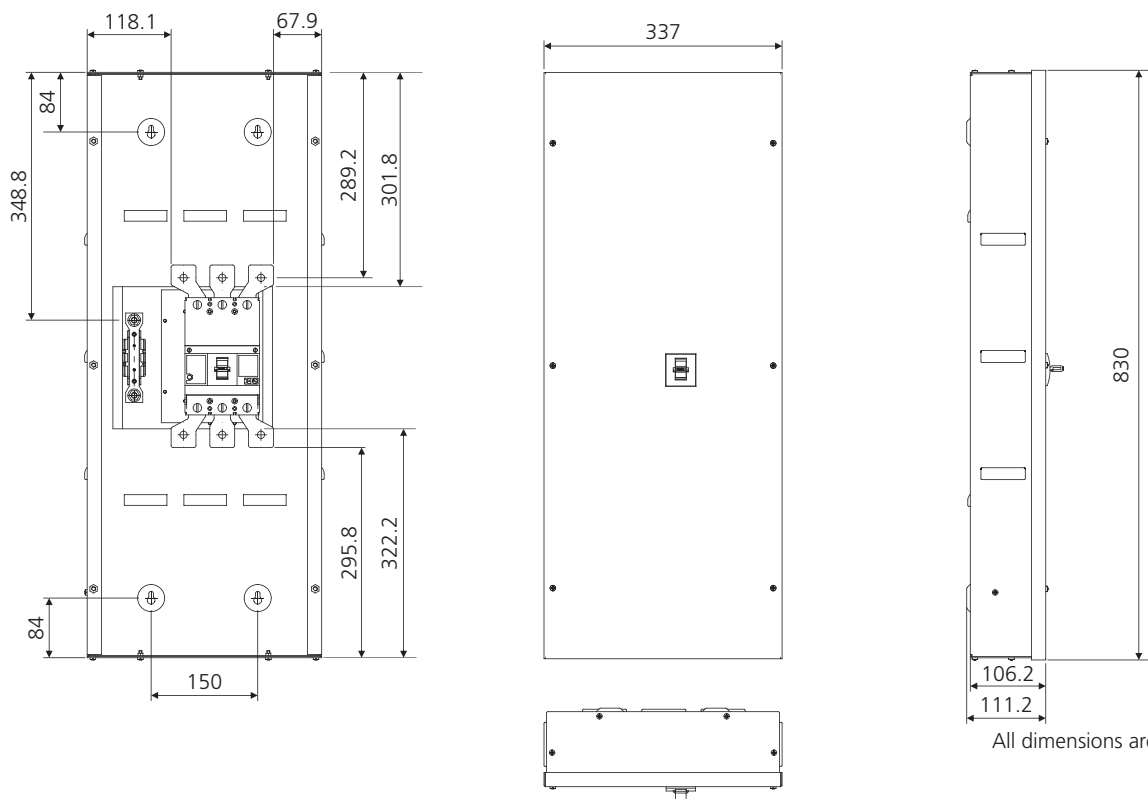

All dimensions are in mm

Get the Switchgear Training Edge!

Aimed at maximizing productivity, conserving energy, minimizing costs and enhancing safety, our Electrical & Automation training programmes have benefitted over 1.35 Lakh professionals in the last 28 years. These training programmes are highly beneficial as they provide right exposure and impart knowledge on selection, installation, maintenance and testing of Electrical & Automation Products.

So gain the advantage and go the extra mile with:

- 22 courses on contemporary topics
- Courses applicable to all switchgear brands
- Training Centers in Pune, Lucknow, Coonoor, Vadodara, Delhi & Kolkata
- Blend of theory and practical experience

The typical training programmes cover:

- Low Voltage & Medium Voltage Switchgear
- Switchboard Electrical Design
- AC Drives & Building Management Solutions
- Protective Relays, Earthing, Reactive Power Management & Harmonics
- Energy Conservation & Management

Please contact any of the training centres for participation and detailed training programme schedule.



Pune

Larsen & Toubro Limited
Switchgear Training Centre,
T-156/157, MIDC
Bhosari, Pune - 411 026
Tel: 020 2712 0037 / 2712 0653
Fax: 020 2712 2933
E-mail: stc-pune@Lntebg.com



Lucknow

Larsen & Toubro Limited
Switchgear Training Centre,
C - 6 & 7, UPSIDC
P. O. Sarojinagar,
Lucknow - 226 008
Tel: 0522 247 6015 / 97944 54455
Fax: 0522 247 6015
E-mail: stc-lucknow@Lntebg.com



Coonoor

Larsen & Toubro Limited
Switchgear Training Centre,
Ooty-Coonoor Main Road
Yellanahalli P.O.,
The Nilgiris - 643 243
Tel. : 0423 251 7107
Fax : 0423 251 7158
E-mail: stc-coonoor@Lntebg.com



Vadodara

Larsen & Toubro Limited
Switchgear Training Centre
Behind L&T Knowledge City,
Near Village Ankhola,
Vadodara - 390019
Tel: 0265 2457805
E-mail: stc-vadodara@Lntebg.com



Delhi

Larsen & Toubro Ltd
Switchgear Training Centre
32, Shivaji Marg,
Near Motinagar Metro Station,
New Delhi - 110015
Tel: 011 41419515 / 41419695 / 41419500
Fax: 011 41419600
E-mail: stc-delhi@Lntebg.com



Kolkata

Larsen & Toubro Limited
Switchgear Training Centre
4th Floor, 3B, Shakespeare Sarani,
Kolkata - 700071
Tel: 033 42005975 / 42005978
E-mail: stc-kolkata@Lntebg.com

Electrical Standard Products (ESP) Offices:

HEAD OFFICE

L&T Business Park,
Tower 'B' / 3rd Floor
Saki Vihar Road, Powai
Mumbai 400 072
Tel: 022-67053229
Fax: 022-67051112
e-mail: cic@LNTEBG.com

BRANCH OFFICES

501, Sakar Complex I
Opp. Gandhigram Rly. Station
Ashram Road
Ahmedabad 380 009
Tel: 079-66304006-11
Fax: 079-66304025
e-mail: esp-ahm@LNTEBG.com

38, Cubbon Road, P. O. Box 5098
Bengaluru 560 001
Tel: 080-25020100 / 25020324
Fax: 080-25580525
e-mail: esp-blr@LNTEBG.com

131/1, Zone II
Maharana Pratap Nagar
Bhopal 462 011
Tel: 0755-3080511 / 05 / 08 / 13 / 17 / 19
Fax: 0755-3080502
e-mail: esp-bho@LNTEBG.com

Plot No. 559, Annapurna Complex
Lewis Road
Bhubaneswar 751 014
Tel: 0674-6451342 / 2436690 / 2436696
Fax: 0674-2537309
e-mail: esp-bsr@LNTEBG.com

Aspire Towers, 4th Floor
Plot No. 55, Phase-I
Industrial & Business Park
Chandigarh-160 002
Tel: 0172-4646840 / 41 / 42 / 46 / 53
Fax: 0172-4646802
Email: esp-chd@Lntebg.com

L&T Construction Campus
TC-1 Building, II Floor
Mount-Poonamallee Road
Manapakkam
Chennai 600 089
Tel: 044-2270 6800
Fax: 044-22706940
e-mail: esp-maa1@LNTEBG.com

67, Appuswamy Road
Post Bag 7156
Opp. Nirmala College
Coimbatore 641 045
Tel: 0422-2588120 / 1 / 5
Fax: 0422-2588148
e-mail: esp-cbe@LNTEBG.com

Khairasol, Degaul Avenue
Durgapur 713 212
Tel: 0343-2540448 / 2540449 / 2540443
Fax: 0343-2540442
e-mail: esp-dgp@LNTEBG.com

5, Milanpur Road, Bamuni Maidan
Guwahati 781 021
Tel: +91 8876554417
Fax: 361-2551308
e-mail: esp-ghy@LNTEBG.com

II Floor, Vasantha Chambers
5-10-173, Fateh Maidan Road
Hyderabad 500 004
Tel: 040-67015052
Fax: 040-23296468
e-mail: esp-hyd@LNTEBG.com

Monarch Building, 1st Floor
D-236 & 237, Amrapali Marg
Vaishali Nagar
Jaipur 302 021
Tel: 0141-4385914 to 18
Fax: 0141-4385925
e-mail: esp-jai@LNTEBG.com

Akashdeep Plaza, 2nd Floor
P. O. Golmuri
Jamshedpur 831 003
Jharkhand
Tel: 0657-2312205 / 38
Fax: 0657-2341250
e-mail: esp-jam@LNTEBG.com

Skybright Bldg; M. G. Road
Ravipuram Junction, Ernakulam
Kochi 682 016
Tel: 0484-4409420 / 4 / 5 / 7
Fax: 0484-4409426
e-mail: esp-cok@LNTEBG.com

3-B, Shakespeare Sarani
Kolkata 700 071
Tel: 033-42005982
Fax: 033-22821025 / 7587
e-mail: esp-ccu@LNTEBG.com

A28, Indira Nagar, Faizabad Road
Lucknow 226 016
Tel: 0522-4929905 / 04
Fax: 0522-2311671
e-mail: esp-Lko@LNTEBG.com

No: 73, Karpaga Nagar, 8th Street
K. Pudur
Madurai 625 007
Tel: 0452-2567405 / 2561068 / 2561657
Fax: 0452-2567552
e-mail: esp-mdu@LNTEBG.com

L&T Business Park,
Tower 'B' / 3rd Floor
Saki Vihar Road, Powai
Mumbai 400 072
Tel: 022-67052874 / 2737 / 1156
Fax: 022-67051112
e-mail: esp-bom@LNTEBG.com

12, Shivaji Nagar
North Ambajhari Road
Nagpur 440 010
Tel: 0712-2260012 / 6606421
Fax: 2260030 / 6606434
e-mail: esp-nag@LNTEBG.com

32, Shivaji Marg
P. O. Box 6223
New Delhi 110 015
Tel: 011-41419514 / 5 / 6
Fax: 011-41419600
e-mail: esp-del@LNTEBG.com

L&T House
P. O. Box 119
191/1, Dhole Patil Road
Pune 411 001
Tel: 020-66033395 / 66033279
Fax: 020-26164048 / 26164910
e-mail: esp-pnq@LNTEBG.com

Crystal Tower,
4th Floor, G. E. Road
Telibandha
Raipur - 492 006
Tel: 0771-4283214
e-mail: esp-raipur@LNTEBG.com

3rd Floor
Vishwakarma Chambers
Majura Gate, Ring Road
Surat 395 002
Tel: 0261-2473726
Fax: 0261-2477078
e-mail: esp-sur@LNTEBG.com

Radhadaya Complex
Old Padra Road
Near Charotar Society
Vadodara 390 007
Tel: 0265-6613610 / 1 / 2
Fax: 0265-2336184
e-mail: esp-bar@LNTEBG.com

Door No. 49-38-14/3/2, 1st floor,
NGGO's Colony, Akkayyapalem,
Visakhapatnam - 530 016
Tel: 0891-2791126 / 2711125
Fax: 0891-2791100
Email: esp-viz@LNTEBG.com

Product improvement is a continuous process. For the latest information and special applications, please contact any of our offices listed here.



Larsen & Toubro Limited, Electrical Standard Products

Powai Campus, Mumbai 400 072

Customer Interaction Center (CIC)

BSNL / MTNL (toll free) : 1800 233 5858 Reliance (toll free) : 1800 200 5858

Tel : 022 6774 5858

E-mail : cic@Lntebg.com / Website www.Lntebg.com

Registered Office: L&T House, N. M. Marg, Ballard Estate, Mumbai 400 001, INDIA **CIN:** L99999MH1946PLC004768

SP 50584 R8